

GIOVANNI BARBIERI  
ARTISAN TILE AND STONE DESIGNER

Perseverant Passion  
Timeless trend...

2018

# INDEX

## WHY

EVERYTHING START WITH NATURAL STONE ALMOST 40 YEARS AGO... AS FAMILY TRADITION AND ESPECIALLY BECAUSE ITALIAN MARBLE IS TIMELESS TREND, ESPECIALLY ANTIQUED: THIS IS WHY ANTIQUED POLISHED AND TIME-WORN WAS CREATED FOR OLD VENETIAN AREA HOUSES RENOVAL; THAN THANKS OF SOME APPLICATION WAS NOT POSSIBLE TO BE MADE IN NATURAL STONE, IS BECAUSE ENGINEERED MARBLE WAS CREATED TAKING ADVANTAGE OF THIS PROCESS FOR CREATE 3D WALLS IMPOSSIBLE OR WITH "LUNAR" COST TO BE MADE IN NATURAL. THAN MURANO GLASS WAS INCLUDED IN OUR DEVELOPMENT FOR IT'S BEAUTY ESPECIALLY ON OPALINE AND WHITE SILK TRANSLUCENT-BACKLIT COLOR TOGETHER HANDMADE TERRACOTTA IN RARE SHADES THAT ARE POSSIBLE TO HAVE FROM A VERY FEW ITALIAN ARTISANS, ONLY. PORCELAIN TILE COLLECTION FOLLOW THEM TO OFFER MORE DEMOCRATIC ACCESS AT OUR UNIQUE SURFACES .

HANDMADE BLACK TERRACOTTA WITH LATEST ADVANGARD ANTIQUED TREATMENT FINALLY OFFER A EASY MAINTENANCE, BLACK SURFACE AS NEVER HAPPENED BEFORE. SIZES ARE DEVELOPED FOR MINIMALIST RUSTIC INTERIOR DESIGN..... THIS IS THE LAST STEP.

BY THE GIOVANNI BARBIERI DESIGN POSITIVE RESPONCE AND AWARDS WON,  
WE ARE NOW PROUD TO COOPERATING WITH OUR TRUST FACTORIES IN FRANCE, INDIA, ITALY, USA  
WHERE GIOVANNI BARBIERI DESIGN ARE SOLD DIRECTLY FROM FACTORY TO YOU .  
WE ALSO HAVE EXCLUSIVE DISTRIBUTORS ESPECIALLY IN NORTH AMERICA, AUSTRALIA, INDIA WHERE SOME  
COLLECTIONS ARE IN STOCK READY TO SHIP.

WE WILL BE HAPPY TO HELP YOU DESIGN AND PRODUCE YOUR PROJECT  
IN THE BEST WAY YOU COULD DESIRE,  
EVEN FOR A UNIQUE EXCLUSIVE DESIGN AND CUSTOM MADE SINGLE PRODUCTION FOR YOU, ONLY.

### **PAGE 3: TRILOGY 3D WORLD FIRST PORCELAIN TILES AWARD WINNER**

PAGE 5 : CINDER  
PAGE 9 : TORTORA  
PAGE 11 : KONA  
PAGE 13 : ULTRA WHITE

### **PAGE 17: 3D WALL NATURAL STONE**

PAGE 19 : AMBRA AWARD WINNER ( PORCELAIN VERSION AT PAGE 177).  
PAGE 23 : MADISON  
PAGE 25 : AMUR  
PAGE 27 : VENICE LEAVES  
PAGE 29 : CLAS ( AWARD WINNER )

### **PAGE 31: 3D WALL ENGINEERED MARBLE - PLASTER**

PAGE 33 : BOREAL.  
PAGE 35 : EXCITON - HIVE  
PAGE 41 : RINEMI  
PAGE 43 : SOLID MOSAIC  
PAGE 47 : RR  
PAGE 53 : TRIFACE  
PAGE 57 : FLORA

### **PAGE 61: SOPHISTICATED SIMPLICITY SERIES**

PAGE 63 : FLOWAYS, TILES, MOSAIC AND 3D  
PAGE 67 : SQUARED TILES, MOSAICS, 3D

### **PAGE 87: DRAFT & BACCHETTE COLLECTION**

### **PAGE 95: DEPTHILE**

### **PAGE 103: ANTIQUED NATURAL STONE TILES**

PAGE 105 : HISTORICAL FLOORS - BLUETTE TIMEWORN  
PAGE 107 : TIMEWORN TILES  
PAGE 109 : TIMEWORN PEPPER GREY TILES  
PAGE 111 : BIANCO ANTICO TIMEWORN TILES , STAIRS & MOSAICS  
PAGE 115 : TIMEWORN MOSAICS & ETCHED TILES

### **PAGE 123: STONE CHOCOLATE BORDERS**

### **PAGE 125: ITALIAN PORCELAIN TILES TIMEWORN MARBLE LOOK.**

PAGE 127: MEMENTO COLLECTION AWARD WINNER  
PAGE 131 : VINTAGE CALACATTA & FOSSANA

### **PAGE 137: ITALIAN ANTIQUED HANDMADE TERRACOTTA.**

PAGE 139: MINIMAL RUSTIC: ANTIQUED BLACK TERRACOTTA.

### **PAGE 141: EXTERIOR NATURAL STONE FLOORS-**

### **PAGE 143 : MURANO COLLECTION BACKLIT WALL PANELS. AWARD WINNER**

PAGE 149 : SAINT GERMAIN.  
PAGE 153 : OBLIO  
PAGE 155 : CLAS  
PAGE 157: HEX  
PAGE 159 : DNA  
PAGE 161 : FLORA  
PAGE 163 : SIN  
PAGE 165 : TEFI  
PAGE 167 : HERAMOSIA  
PAGE 169 : NOTRE DAME  
PAGE 171 : MILAN FLOREAL  
PAGE 173 : SOPHIE BY SARA BALDWIN  
PAGE 177 : INSTALLATION OPTIONS

### **PAGE 179: ART WORK WITH ROBERTO LANARO METAL SCULPTOR**

### **PAGE 191: POP ART - ROMERO BRITTO**



## THE WORLD'S FIRST REAL 3D PORCELAIN TILE.

TRILOGY BY GIOVANNI BARBIERI IS AN UTTERLY UNIQUE PRODUCT WITH THE FOLLOWING CHARACTERISTICS:

TRILOGY COLLECTION, THE WORLD'S FIRST 3D PORCELAIN TILE IS 2016 BEST OF YEAR INTERIOR DESIGN USA AWARD WINNER ON WALLCOVERINGS TILE & STONE 3D CATEGORY.

THIS PRESTIGIOUS AWARD IS GIVEN BY THE MOST RENOWNED AMERICAN MAGAZINE CALLED INTERIOR DESIGN .

- ON DECEMBER 1, 2016 NEARLY 1,000 PEOPLE FROM THE DESIGN COMMUNITY (DESIGNERS AND MANUFACTURERS) GATHERED AT THE STATE-OF-THE-ART FRANK GEHRY DESIGN, IAC BUILDING IN NEW YORK CITY.

TRILOGY COLLECTION ON MAY 2017 AT MUSEUM OF MODERN ART IN NEW YORK CITY WON A 2ND AWARD AS BEST COVERING TILE AT INTERIOR DESIGN MAGAZINE EVENT DURING THE NEW YORK CITY DESIGN WEEK.



- THE WORLD'S FIRST THREE-DIMENSIONAL PORCELAIN TILE MEASURING 2" DEEP HEXAGONAL 6" ( CM 15,0 ) SIDE CHANGING ITS SURFACE THICKNESS FROM 2/8 TO 1\_ 2/3" ( 8 MM TO 45 MM ) IN JUST 11" 4/5 ( 30 CM ) WHICH REPRESENTS THE LARGEST SIDE OF EACH TILE.
- THIS IS ALSO THE FIRST PATTERN WHERE A REGULAR HEXAGONAL TILE, EASE OF INSTALLATION, OBTAINS IRREGULAR RANDOM SHAPES THANKS TO TWO DIFFERENT JOINT WIDTHS GENERATED DURING INSTALLATION.
- THE FASHIONABLE COMBINATION OF THE 3 DIFFERENT TEXTURES APPLIED ON 3 DIFFERENT COLOR SHADES IN 3 DIFFERENT WAYS ON 3 DIFFERENT MODELS, WHICH NEED TO BE INSTALLED RANDOMLY, COMPLETE THE LATEST BARBIERI UTTERLY UNIQUE AESTHETIC RESULT.
- THE 3 MODELS PERMIT TO OBTAIN ON LINEAR PATTERN AND ONE RANDOM PATTERN INSTALLATION.
- INDIVIDUAL CUSTOM ACCENTS ARE AVAILABILE ON DEPTH, COLOURS AND TEXTURES INCLUDING CORNERS AND FRAME ACCESSORIES THANKS TO THE CUSTOMER SERVICE OF BARBIERI DESIGN STUDIO.
- A NEW CONCEPT OF BACKGROUND OR JUST ORNAMENTAL WALL SOLUTION IN BETWEEN A TRADITIONAL FLAT SURFACE AND HIGH STRUCTURED 3D WALLS.
- OFFERING AN EASY MAINTENANCE / CLEANING SURFACE, ALSO SUITABLE FOR ANY LIGHTING AND INSTALLATION ACCESSORIES.
- GUARANTEED FOR ANY EXTERIOR EXTREME CLIMATE CONDITION, WET AREA INSTALLATION OR NEXT TO HIGH-TEMPERATURE SOURCES ( FIREPLACE WALL).

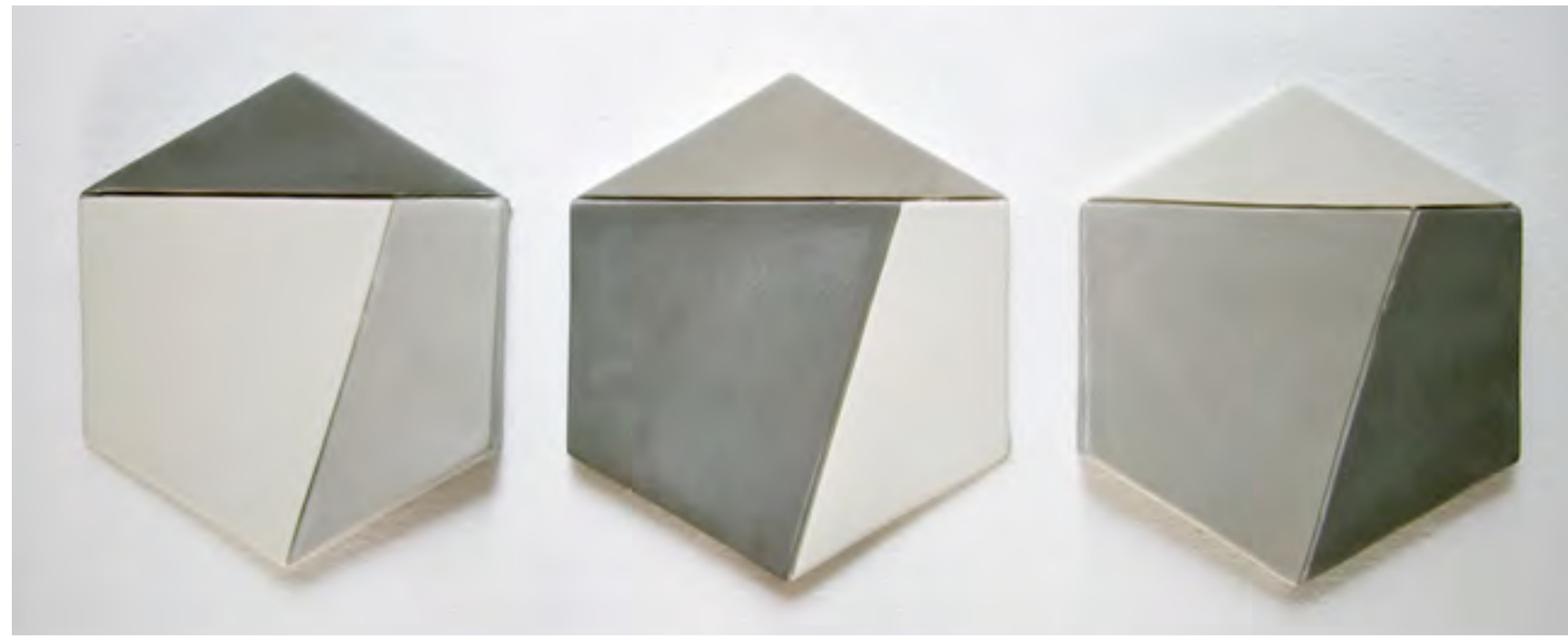

THE FASHIONABLE COMBINATION OF THE 3 DIFFERENT TEXTURES APPLIED ON 3 DIFFERENT COLOR SHADES IN 3 DIFFERENT WAYS ON 3 DIFFERENT MODELS, WHICH NEED TO BE INSTALLED RANDOMLY, COMPLETE THE GIOVANNI BARBIERI UTTERLY UNIQUE AESTHETIC RESULT.

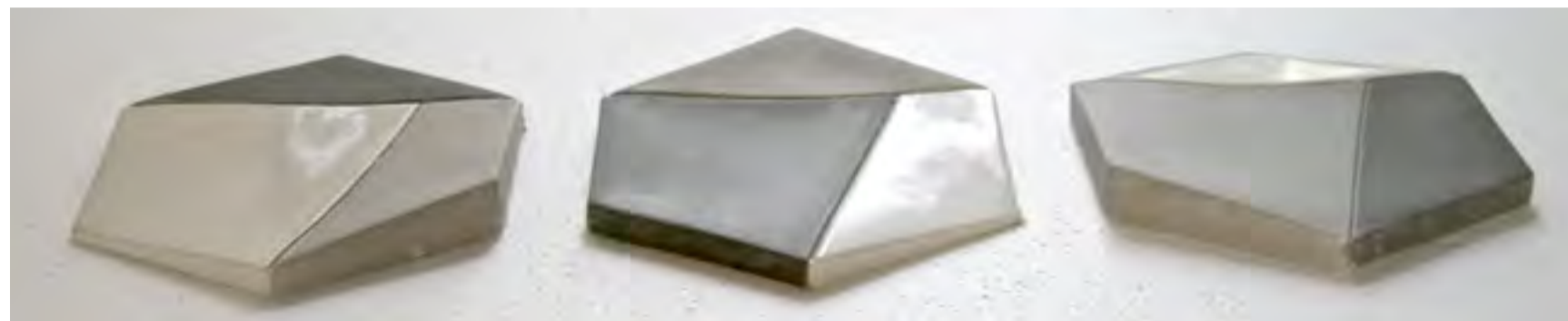

THE WORLD'S FIRST THREE-DIMENSIONAL PORCELAIN TILE MEASURING 1" 1/2 DEEP HEXAGONAL 6" (CM 15,0) SIDE CHANGING ITS SURFACE THICKNESS FROM 2/8 TO 1\_ 1/2" (8 MM TO 38 MM) IN JUST 11" 3/8 ( 30,0 CM ) WHICH REPRESENTS THE LARGEST SIDE OF EACH TILE.

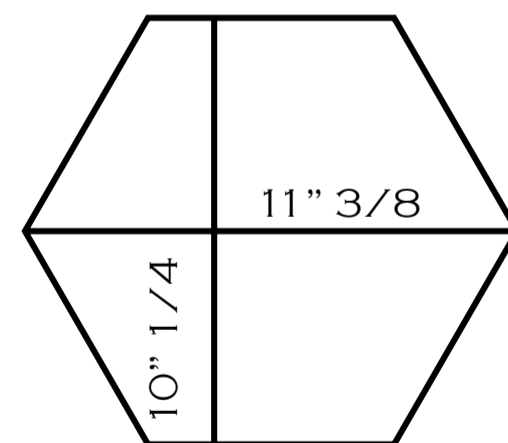
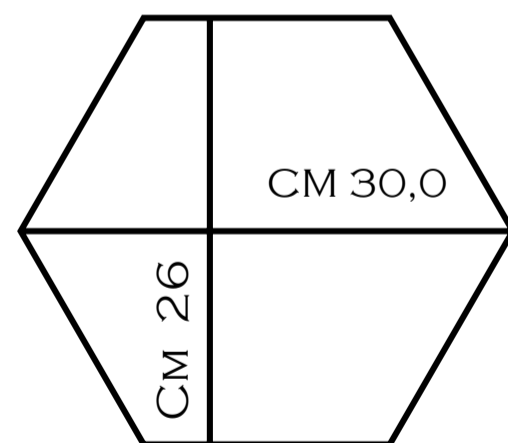

ALL 3 MODELS/TILES HAVE 3 TO 4 MM JOINT IN THE MIDDLE BETWEEN THE 3 SHAPES COMPOSING EACH SINGLE TILE. DURING INSTALATION, SIMPLY ALIGN THE EDGE OF ONE TILE TO THE MATCHING ( SAME LENGHTS THICKNESS ) EDGE OF THE ADJACENT TILE. THIS ALLOWS A SINGLE COLOR AND TEXTURE TO COME TOGETHER, WHILE BEING DEFINED BY THE PERIMETRAL LARGER JOINT.





THE THREE MODELS CAN BE INSTALLED IN A LINEAR OR RANDOM PATTERN.

## Two Patterns on same wall.

CINDER

Triangles are take out for start installation on one vertical side and complete straight on top side with the same in the other side

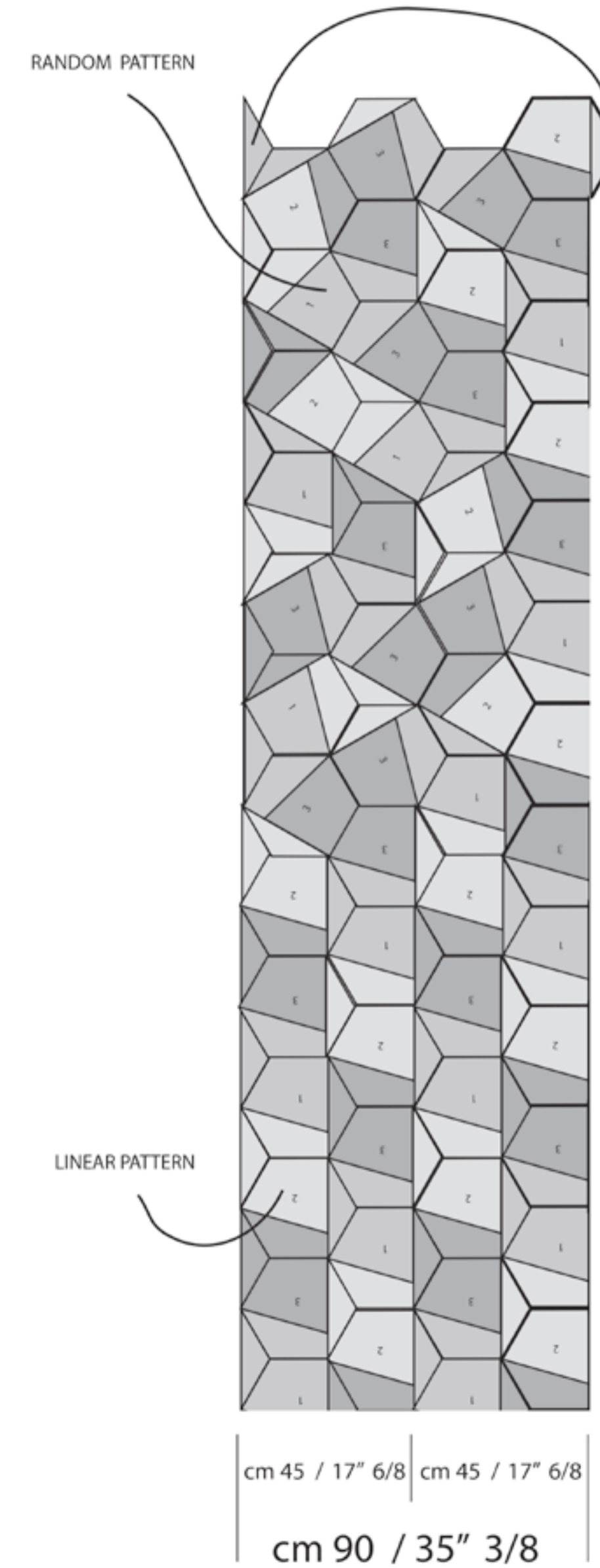

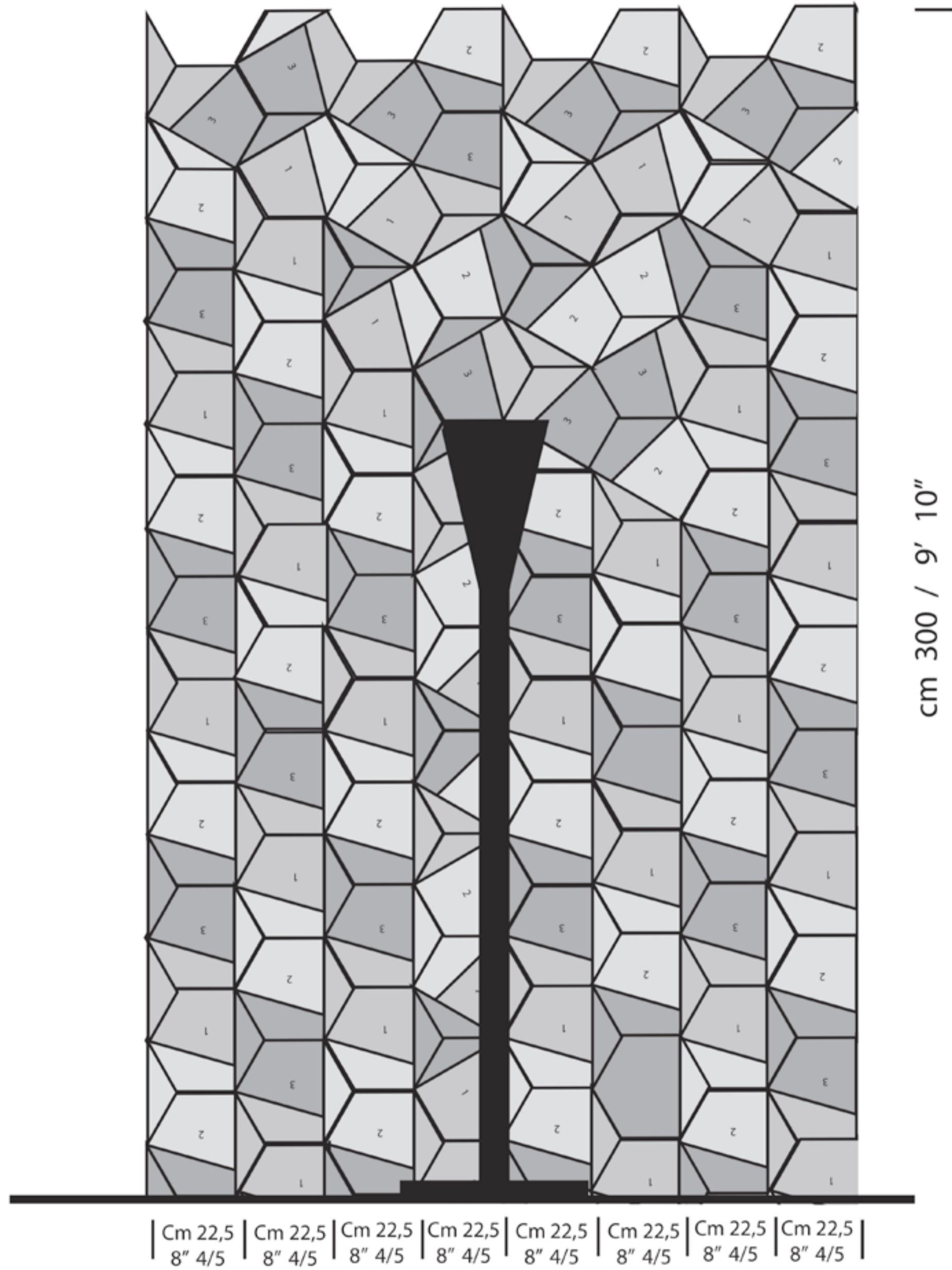

"IT APPEAR THE POWER OF LIGHT IS ABLE TO MOVE THE SHAPES AND JOINTS."



CM 45 / 17" 6/8  
CM 45 / 17" 6/8  
CM 45 / 17" 6/8  
CM 135 / 53"







ULTRA WHITE

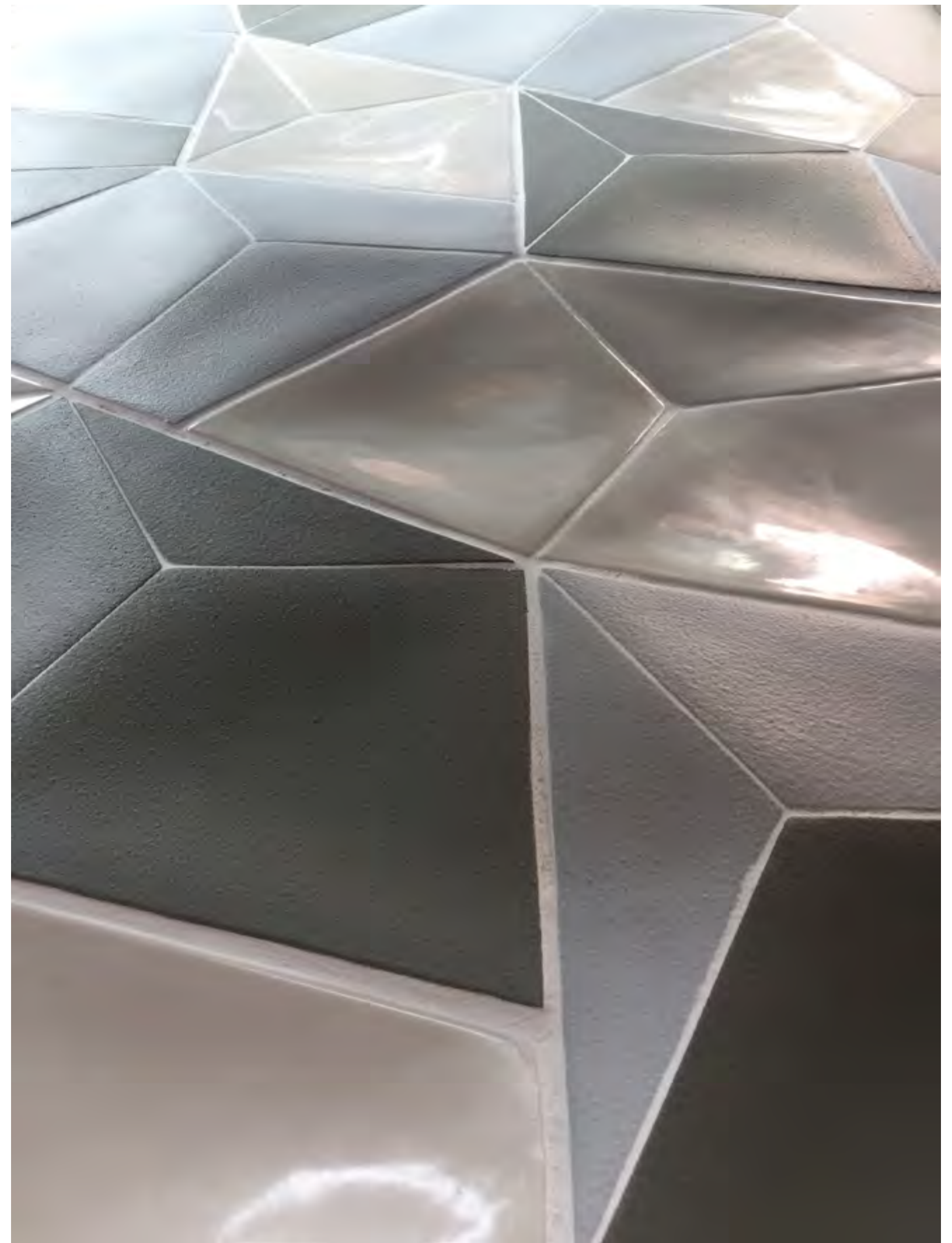

INDIVIDUAL CUSTOM ACCENTS ARE AVAILABILE ON DEPTH, COLOURS AND TEXTURES INCLUDING CORNERS AND FRAME ACCESSORIES THANKS TO THE CUSTOMER SERVICE OF OUR DESIGN STUDIO.

# HANDCARVED NATURAL STONE TILES

GIOVANNI BARBIERI HAS DISCOVERED, INVENTED, DESIGNED AND ESTABLISHED THE PRODUCTION OF CARVED STONES SINCE JANUARY OF 2008. HE HAS WORKED WITH PREMIUM-QUALITY STONE QUARRIED IN INDIA AND HAS OFFERED UNBEATABLE PRICING FOR HIS LUXURIOUS DESIGNS.

THE AMBRA COLLECTION, DESIGNED BY GIOVANNI BARBIERI, IS REGARDED BY MANY CLIENTS AS ONE OF THE MOST WELL-KNOWN AND APPRECIATED CARVED TILE CREATIONS TODAY. THEREFORE, MANY SEEK TO COPY AND REPRODUCE THE DESIGN IN DIFFERENT MATERIALS.

SOPHISTICATED AND COMPLICATED DESIGNS ARE NOW AVAILABLE ON ENGINEERED STONE: 100% MADE IN ITALY, ENGINEERED STONE IS ACHIEVED BY RECYCLING MARBLE DUST RESIDUE THROUGH A USA TESTED LABORATORY PROCESS, THEREBY ACCURATELY REPRODUCING ITS GENUINE ORIGINAL. SUITABLE FOR BOTH INTERIOR AND EXTERIOR APPLICATIONS, THE PRODUCT IS UV-RATED, FROST-RESISTANT, NON-POROUS AND MAINTENANCE-FREE.

SEVERAL DESIGNS ARE ALSO AVAILABLE IN CONCRETE AND GYPSUM, WHICH MAKES THEM SUITABLE FOR ADDITIONAL APPLICATIONS AT A REASONABLE PRICE.

FOR SURE "AMBRA COLLECTION" IS THE MOST FAMOUS; DESIGNED END OF 2007, ON 2008 RECEIVED AMERICAN ARCHITECTURE AWARDS THROUGH "ARCHITECTURAL RECORD" MAGAZINE WHICH DESIGNATED "AMBRA COLLECTION" AMONG ONE OF THE 8 BEST 2008 CONSTRUCTION PRODUCTS IN USA. AMBRA COLLECTION WAS EXPOSED AT "TRIENNALE DESIGN MUSEUM" IN MILAN FOR MORE THAN ONE YEAR.

IT IS A STILL ONE OF BEST SELLER PRODUCT , AND THIS IS WHY WE DECIDE TO INTRODUCE SOON A NEW EVOLVED MODEL CELEBRATING IT'S SUCCESSFULL 10 YEARS OLD. SEE ALSO THE PORCELAIN TILE VERSION AT 127 PAGE .

WE WILL BE HAPPY TO HELP YOU DESIGN AND PRODUCE YOUR PROJECT IN THE BEST WAY YOU COULD DESIRE, EVEN FOR A UNIQUE EXCLUSIVE DESIGN AND CUSTOM MADE SINGLE PRODUCTION FOR YOU, ONLY.

# AMBRA

23" 2/3 x 23" 2/3 x 3/4 CM 60 x 60 x 1,8  
AVAILABLE IN NATURAL STONE, ENGINEERED MARBLE AND PORCELAIN

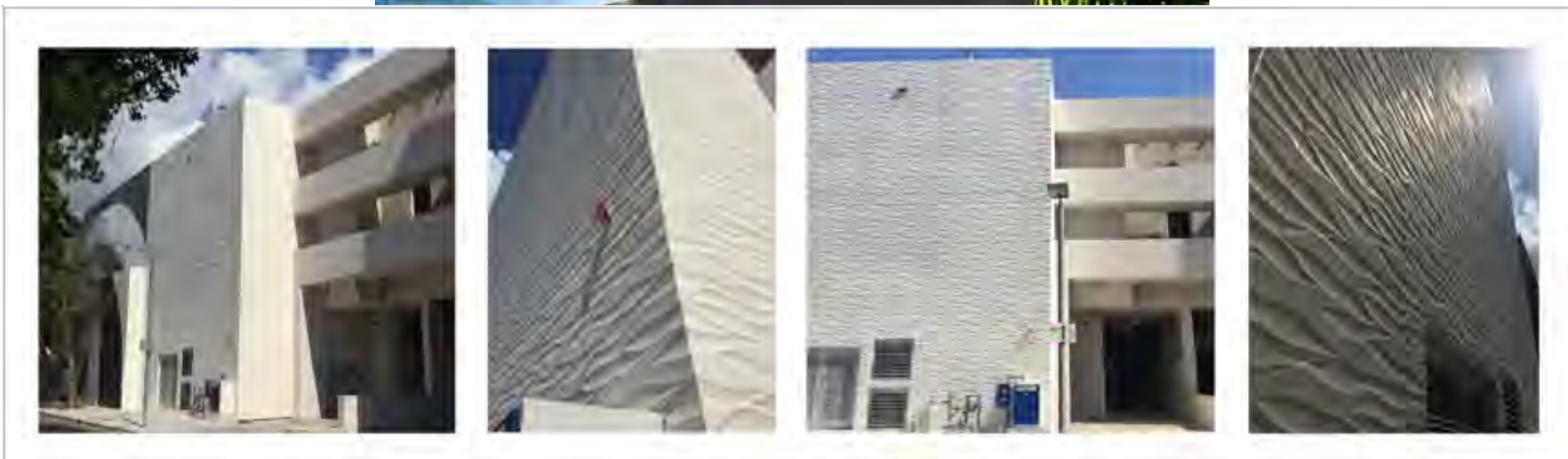

MIAMI DESIGN DISTRICT 2016 / PALM COURT EXTERIOR WALL AT NE 38TH ST.

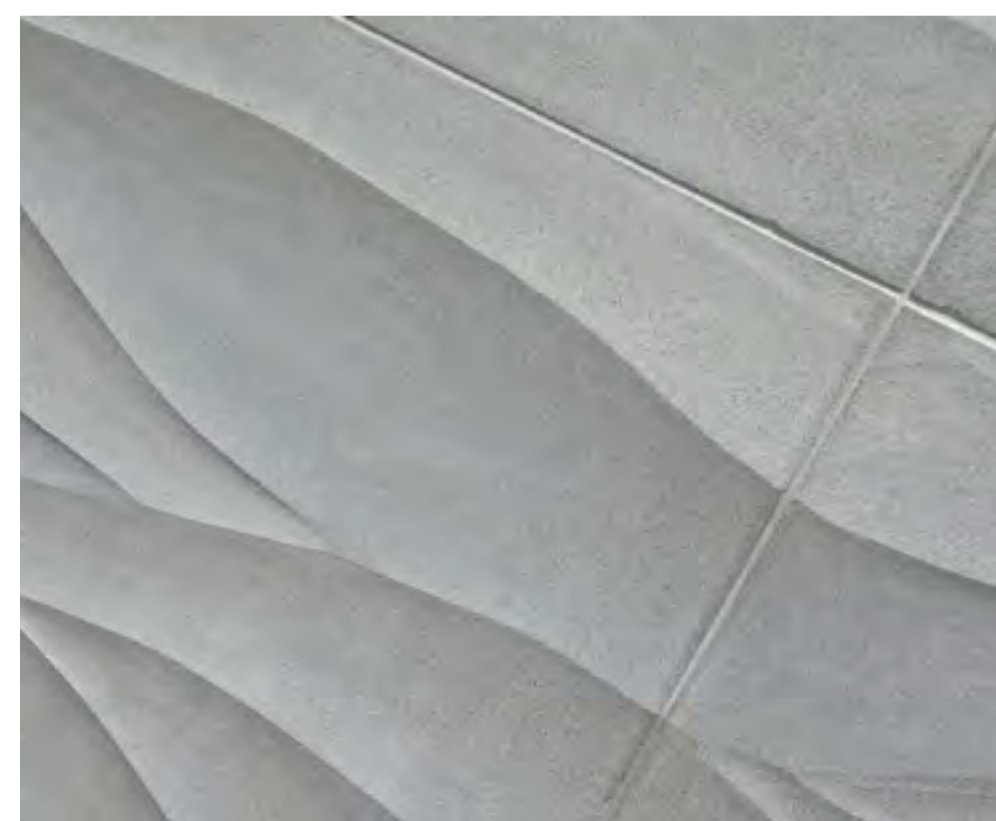

SEE ALSO AMBRA PORCELAIN TILE VERSION AT 127 PAGE

OBLIO  
60X60X1,8 CM  
NATURAL BLACK LIMESTONE

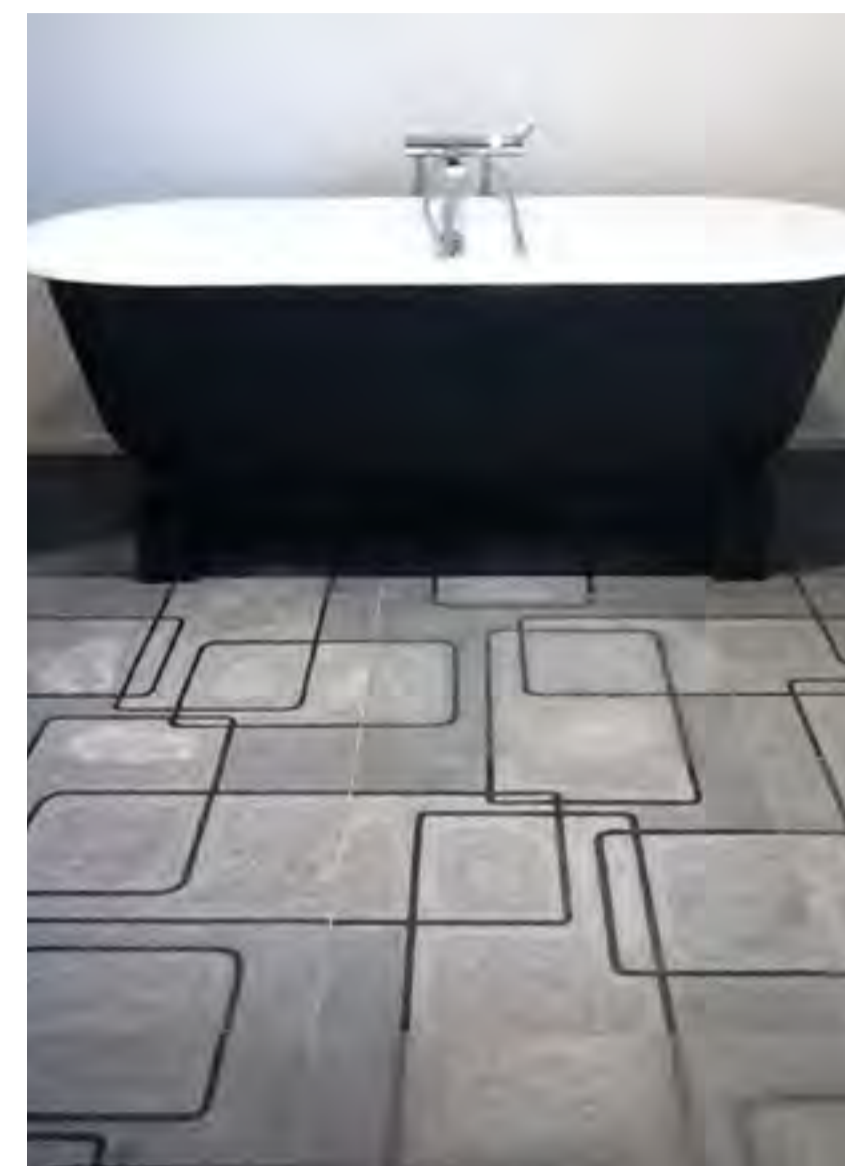

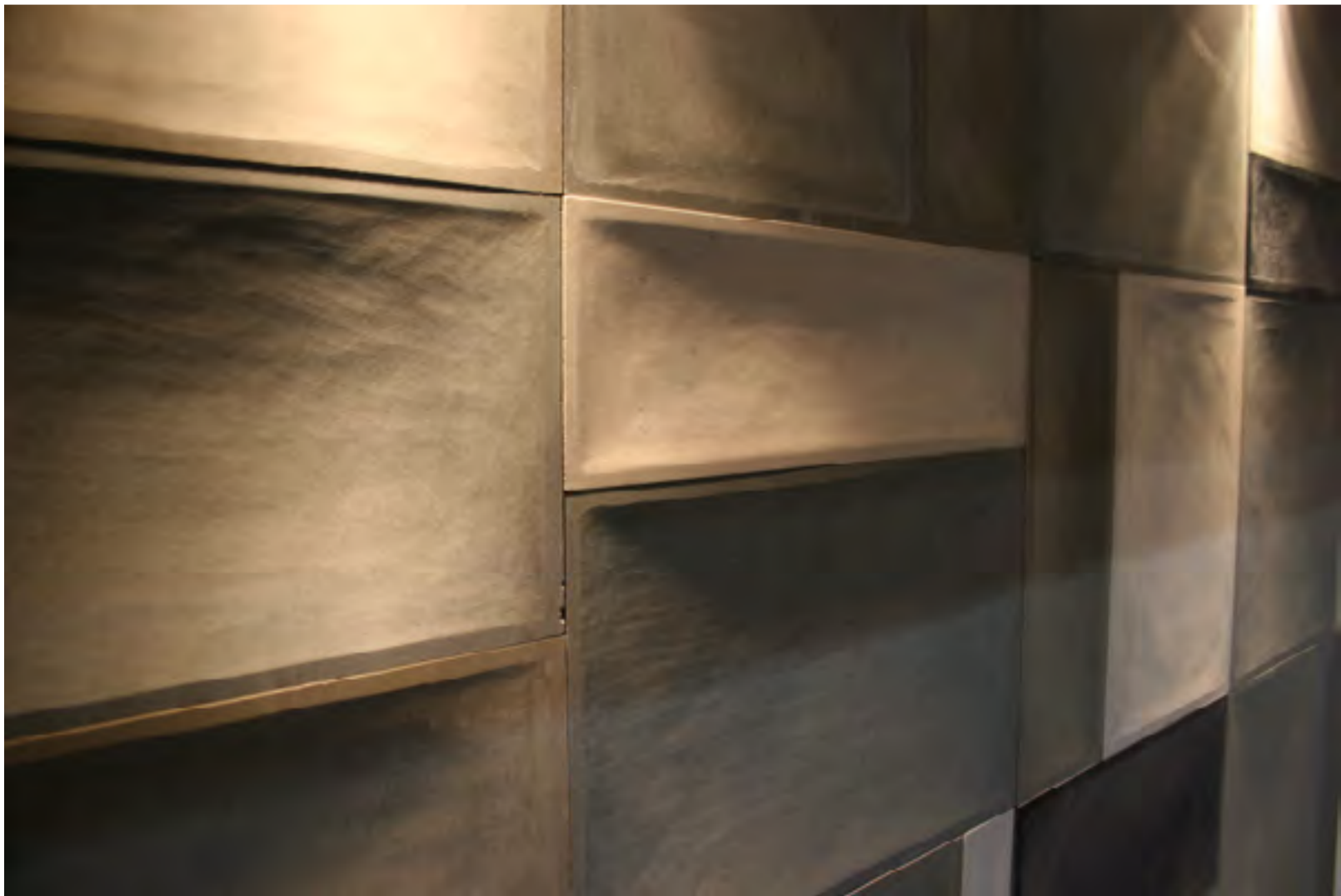

# AMUR

4 SIZES PATTERN : CM 20x20 / 20x40 / 40x40 / 40x60  
LIGHT GREY SANDSTONE THICKNESS CM 2



© COPYRIGHT BY GIOVANNI BARBIERI 1997-2013



# VENICE LEAVES

CUSTOM MADE WATERJET CUT  
LIGHT GREY SANDSTONE

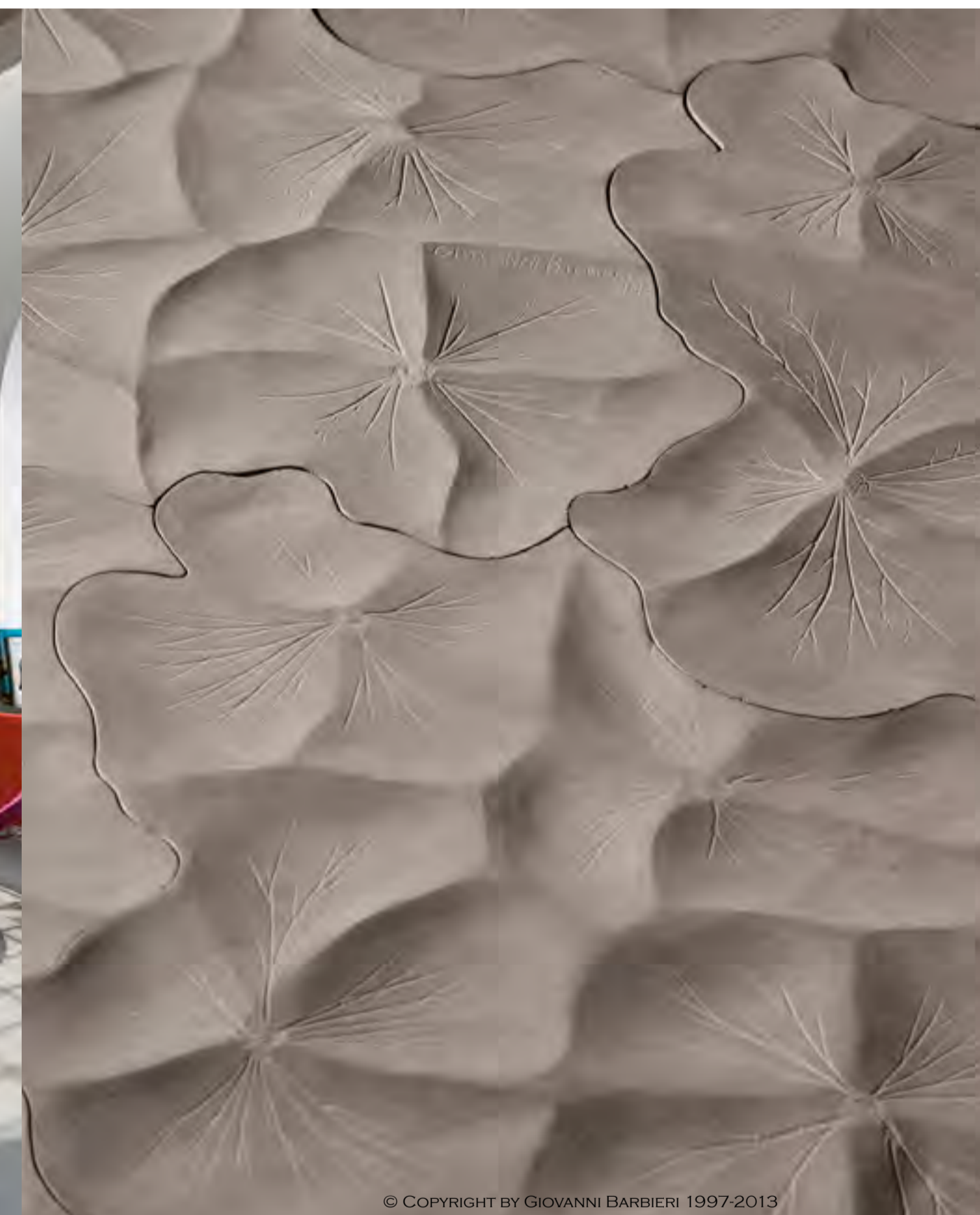

© COPYRIGHT BY GIOVANNI BARBIERI 1997-2013



**SURFACE  
DESIGN  
AWARDS  
WINNER**

LONDON 2014

**CLAS**

40x60x2 CM MODULAR TILES  
NATURAL STONE

FIT TO WALL SIZE CUSTOM MADE AVAILABLE.

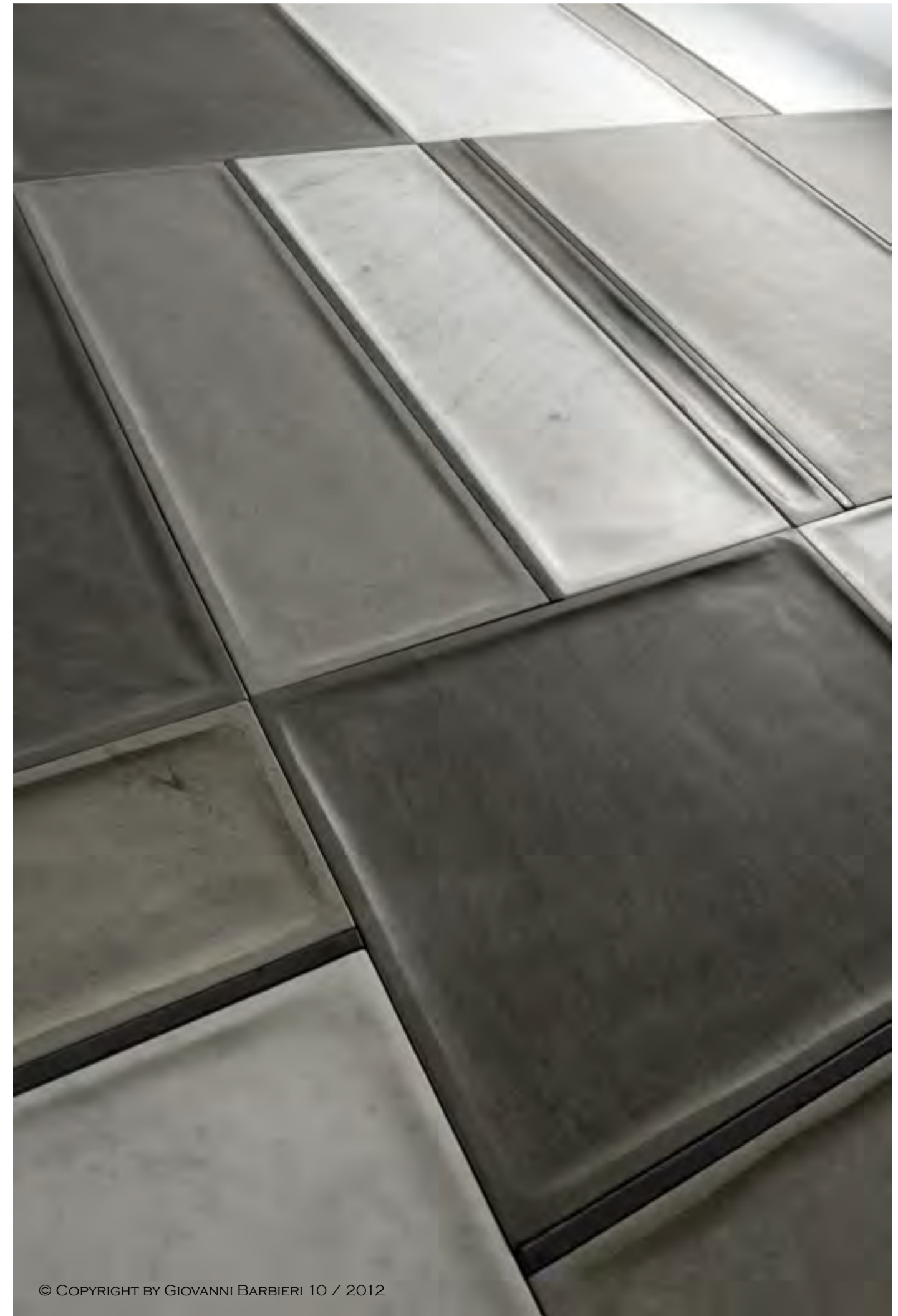

© COPYRIGHT BY GIOVANNI BARBIERI 10 / 2012



# ENGINEERED MARBLE & GYPSUM THREE DIMENSIONAL TILES

THE ENGINEERED MARBLE CARVED TILES ARE PRODUCED, THROUGH A LABORATORY TESTED PROCESS, BY RECYCLING MARBLE DUST FROM THE PRODUCTION WASTE REFUSE THUS FAITHFULLY REPRODUCING THE TRAVERTINE AND NATURAL STONE . SUITABLE FOR ANY INSTALLATION/CLIMATE CONDITION EVEN WHERE NATURAL STONE IS NOT SUGGESTED. NO MAINTENANCE. NOT ABSORBENT. LABORATORY TESTED UNALTERABLE COLOUR FROM UV RADIANT. THIS PROCESS ALSO HELP TO OBTAIN 3D DRAWINGS THAT ARE IMPOSSIBLE TO BE PRODUCED IN NATURAL OR JUST WITH "LUNAR" PRICE.

TO HELP INTERIORS INSTALLATION REDUCE COST ONLY, THE ENGINEERED MARBLE PRODUCTS ARE ALSO AVAILABLE IN GYPSUM AT MUCH MORE REASONABLE COST BUT SUITABLE IN 100% DRY PLACE ONLY WHERE IS POSSIBLE TO PAINT ON SITE AT INSTALLATION COMPLETED.

WE WILL BE HAPPY TO HELP YOU DESIGN AND PRODUCE YOUR PROJECT IN THE BEST WAY YOU COULD DESIRE, EVEN FOR A UNIQUE EXCLUSIVE DESIGN AND CUSTOM MADE SINGLE PRODUCTION FOR YOU, ONLY.

BOREAL

22" 2/3 x 22" 2/3 x 3/4 - CM 57,6 x 57,6 x 2  
ENGINEERED MARBLE

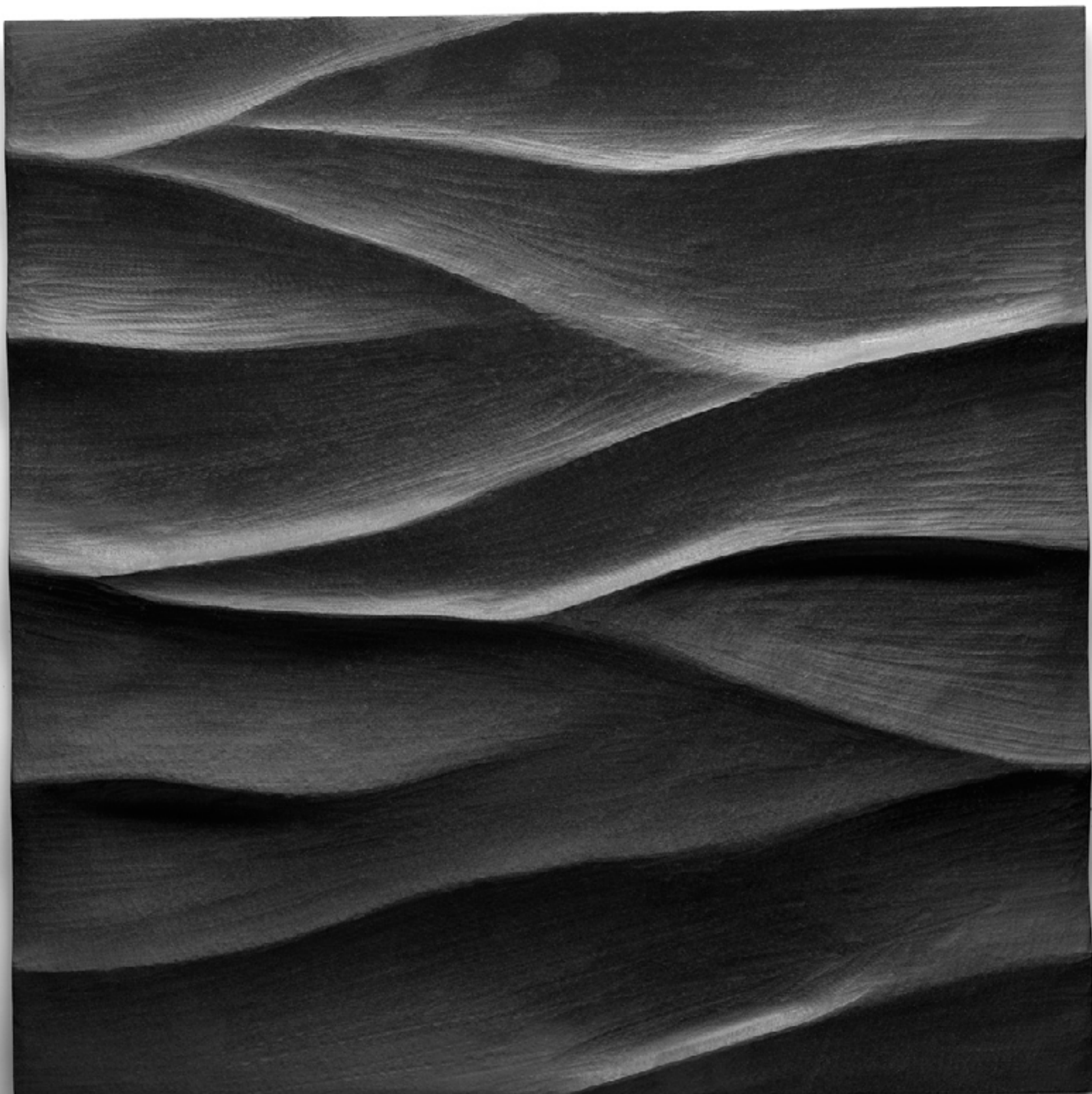

CALIBRATED TILES SIZES CM 57,6 x 57,6 x 2 - 22" 2/3 x 22" 2/3 x 3/4

DARK GREY



BROWN



WHITE

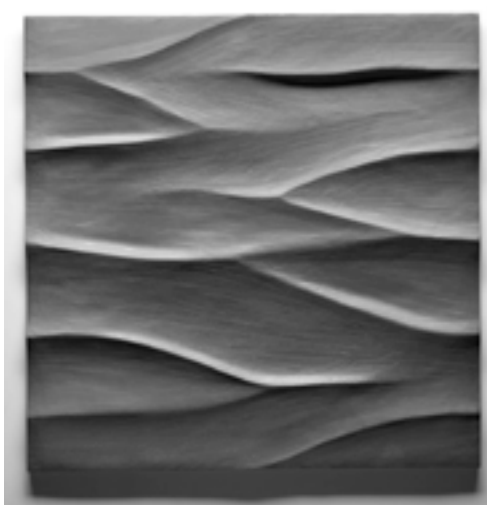

LIGHT GREY



JASMINE

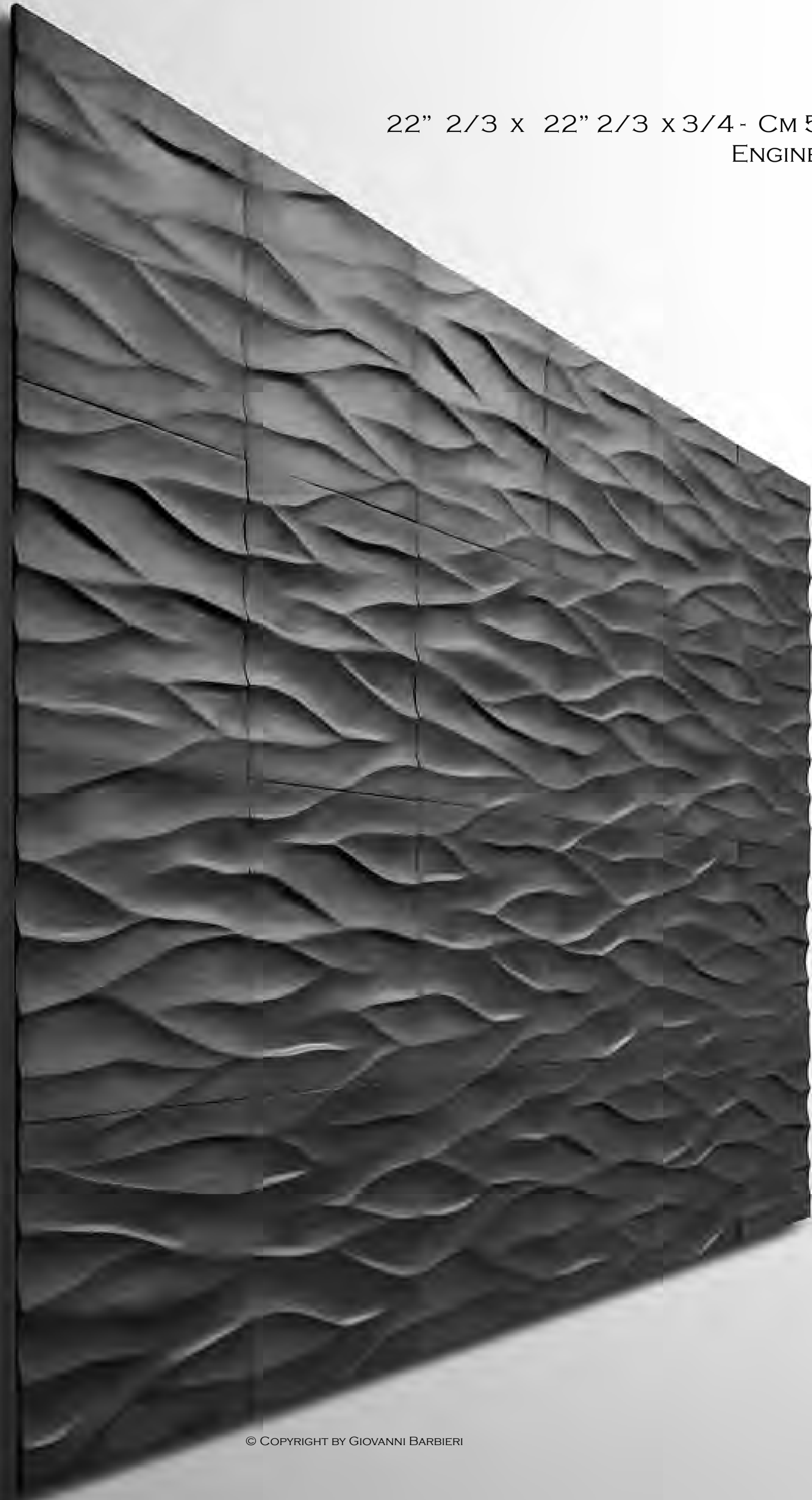



STONE NATURAL L SPLIT

DIMENSION

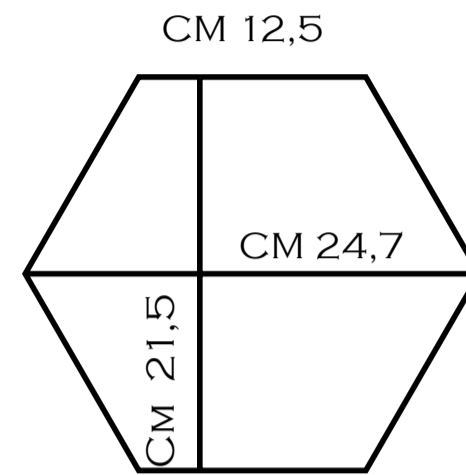

WOOD WHITE ANTIQUED

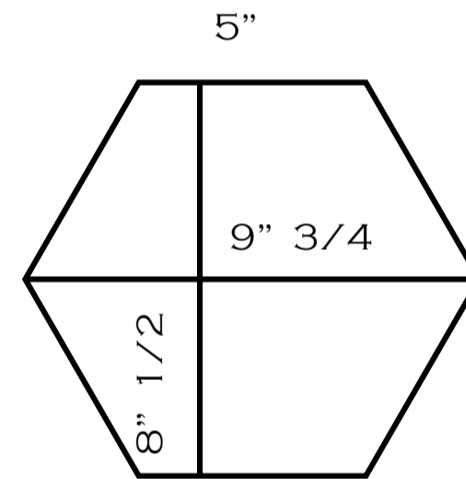

MODEL A

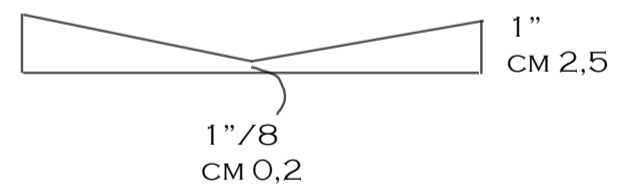

MODEL B

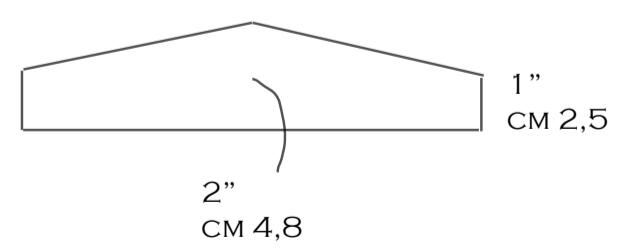

BROWN BURNED WOOD





COURTESY OF REALSTONE SYSTEM USA.



COURTESY OF REALSTONE SYSTEM USA.  
BY REQUEST DIFFERENT MIXED TEXTURES-COLOURS ARE AVAILABLE.



CRAFT CAFE', DESIGN DISTRICT DUBAI.  
COURTESY OF MR. DOMENICO IANNONE.

HOTEL LOBBY, COURTESY OF REALSTONE SYSTEM USA.



**RINEMI**  
 56x60x2 CM  
 ENGINEERED MARBLE  
 (NOT AVAILABLE IN GYPSUM)



BEIGE BOTTICINO



WHITE LIMESTONE

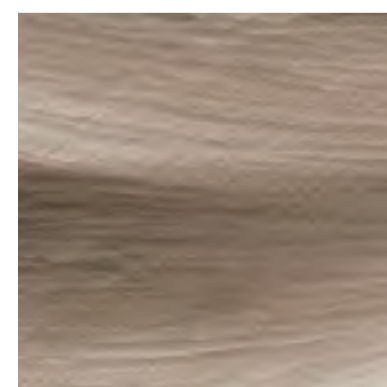

JASMINE

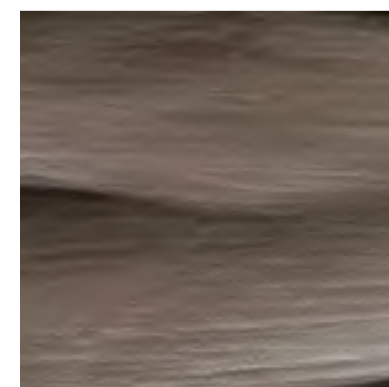

BROWN

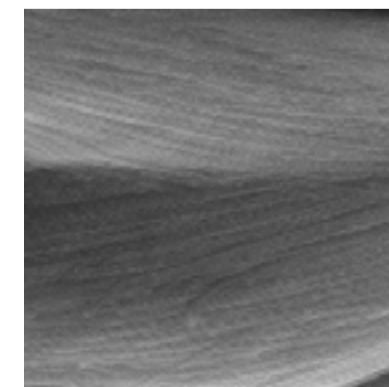

IRON GREY

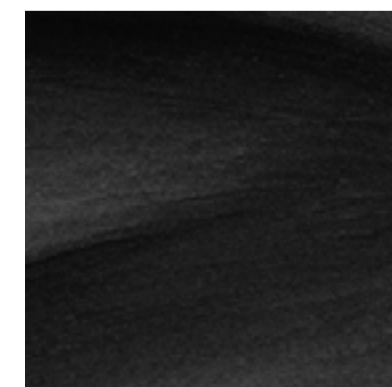

DARK GREY

6 COLOUR OPTIONS

CM 50,0 / 19" 3/4

VERTICAL LIGHTING



THE SAME TILE WITH DIFFERENT LIGHTING DIRECTION

HORIZONTAL LIGHTING



CM 60,0 / 23" 2/3



# SOLID MARBLE MOSAIC

CM 6 x 30 x 1 LOOSE STRIPS OR INTERLOCK PANELS ON NET.  
ENGINEERED MARBLE AND GYPSUM



© COPYRIGHT BY GIOVANNI BARBIERI 09/2012

LIGHT TRAVERTINE



WHITE  
LIMESTONE

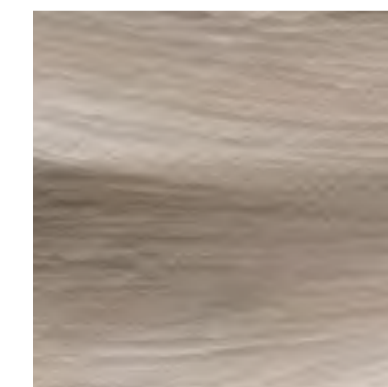

JASMINE

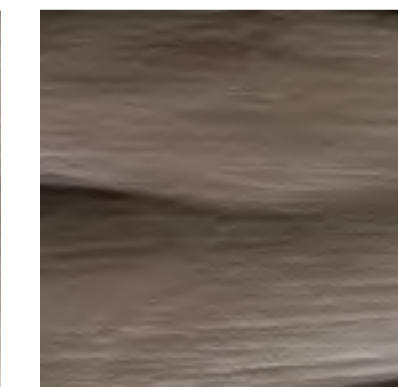

BROWN

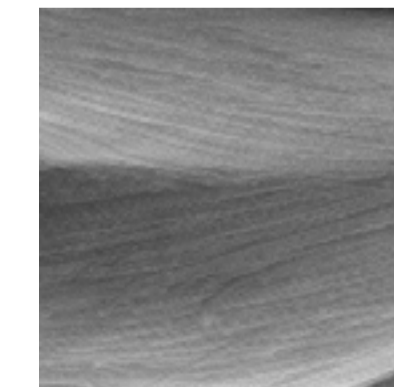

IRON GREY

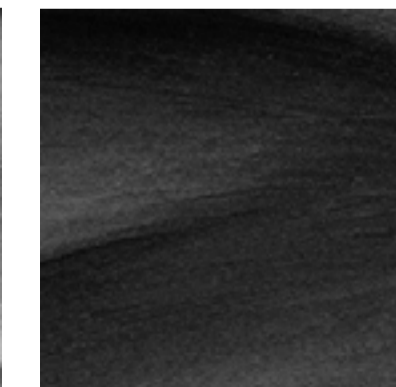

DARK GREY

6 COLOUR OPTIONS



## SOLID MARBLE MOSAIC

6x30x1 CM LOOSE STRIPS OR INTERLOCK PANELS ON NET.  
ENGINEERED MARBLE AND GYPSUM



LIGHT TRAVERTINE / THE NEW SPA AT 5 STARS HOTEL BRISTOL WARSAW, SINCE 1902,



# RR COLLECTION

SHADING WALL FROM FLAT TO LOW OR HIGH CARVED-CONVEX TILES  
 AVAILABLE IN ENGINEERED MARBLE AND PLASTER.  
 WE WILL BE HAPPY TO HELP YOU DESIGN AND PRODUCE YOUR PROJECT  
 IN THE BEST WAY YOU COULD DESIRE,  
 EVEN FOR AN UNIQUE EXCLUSIVE DESIGN AND CUSTOM MADE SINGLE PRODUCTION, ONLY.



PANEL 4 MAX CARVED CONVEX PANEL 4	PANEL 3 MAX + MEDIUM CARVED CONVEX PANEL 3	PANEL 2 FLAT + MEDIUM CARVED CONVEX PANEL 2	PANEL 1 FLAT ONLY PANEL 1
--	---	--	---------------------------------

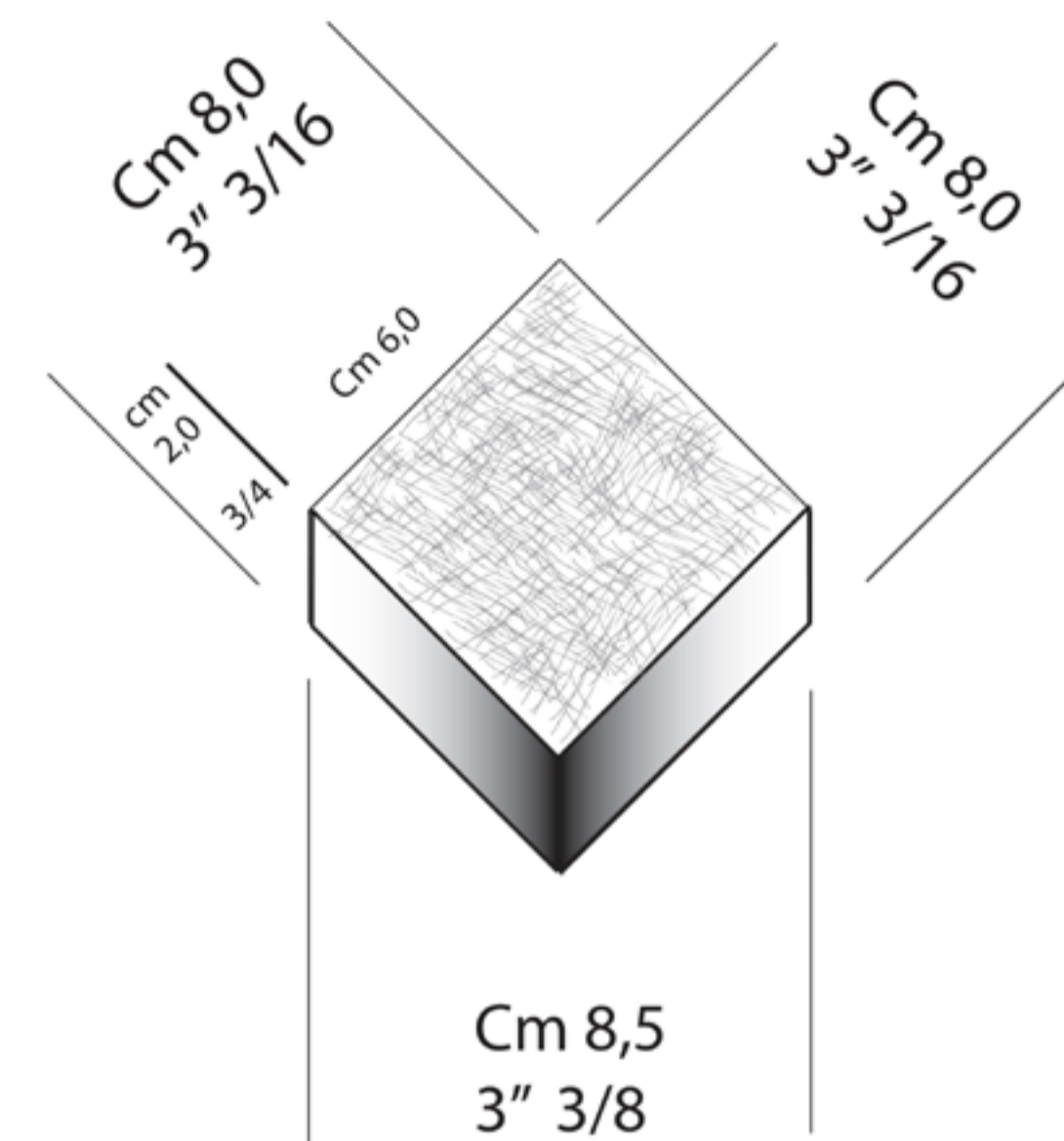

Each panel is composed with 15 tiles:  
 surface cm 36,0 x 25,5 = Mq 0,092 each panel  
 surface 14" 3/16 x 10" = SF 0,99 each panel

## 6 COLOUR OPTIONS



WHITE  
LIMESTONE



BOTTICINO

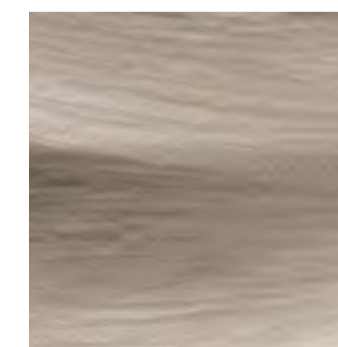

JASMINE

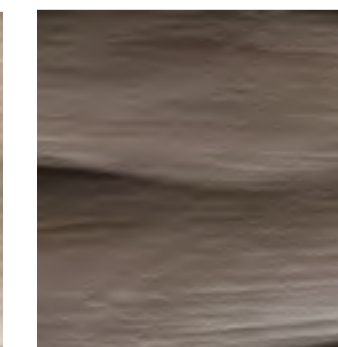

BROWN

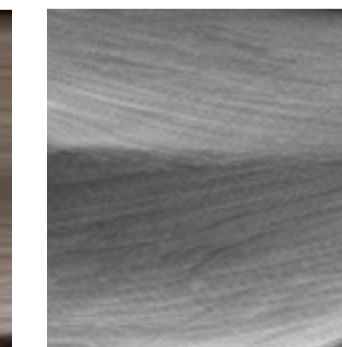

IRON GREY

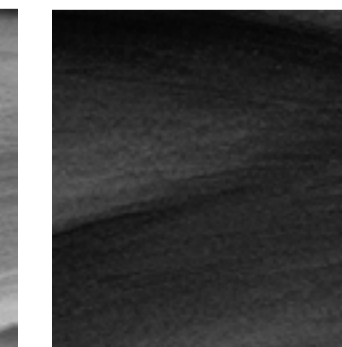

DARK GREY

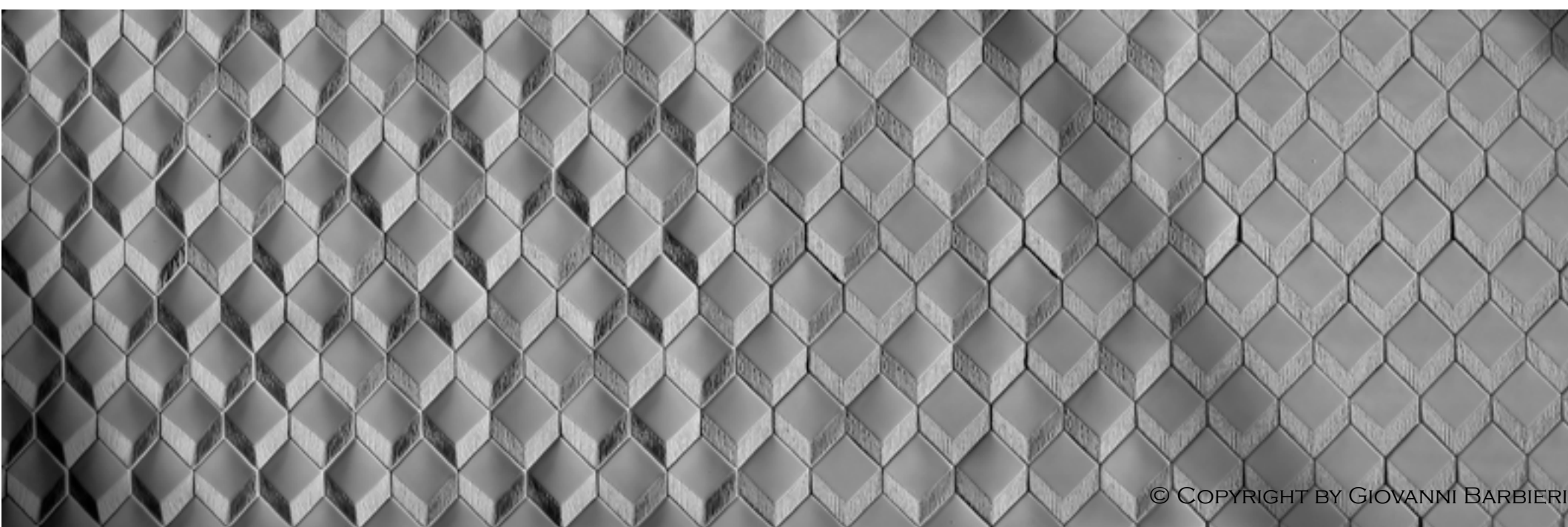

© COPYRIGHT BY GIOVANNI BARBIERI

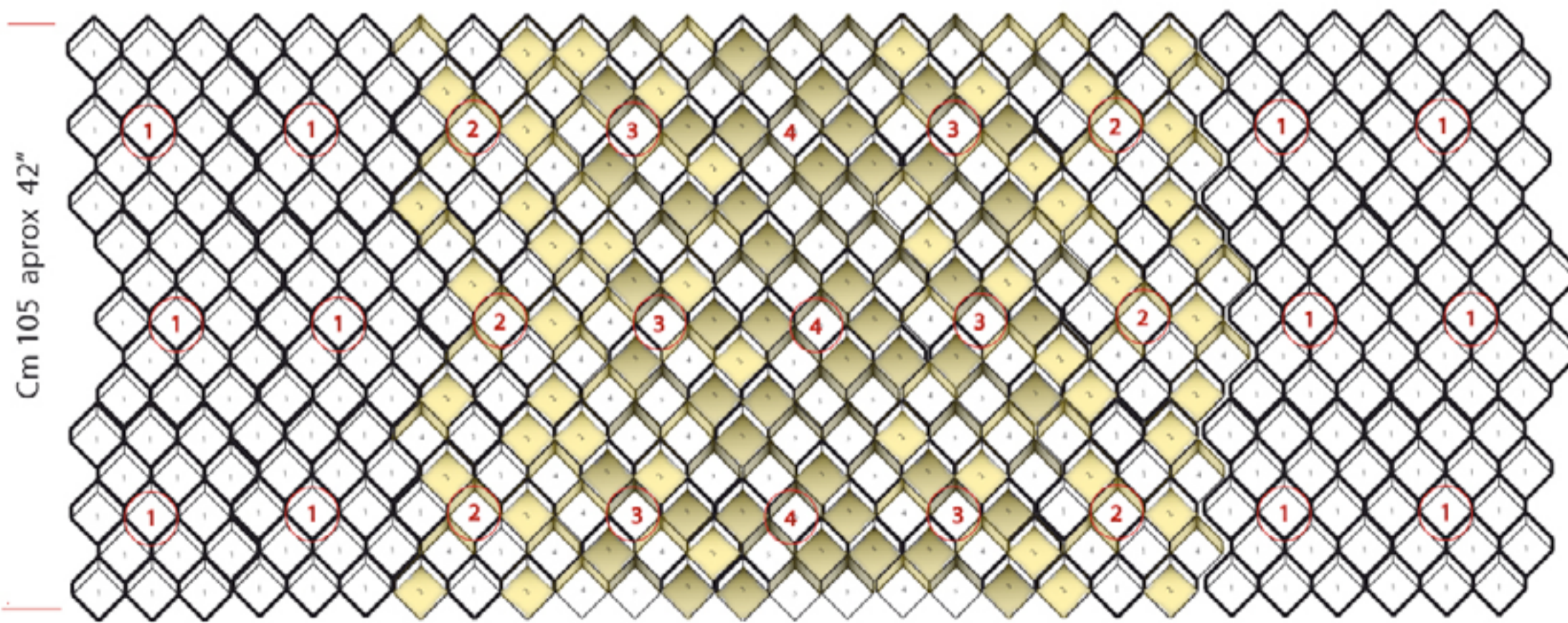
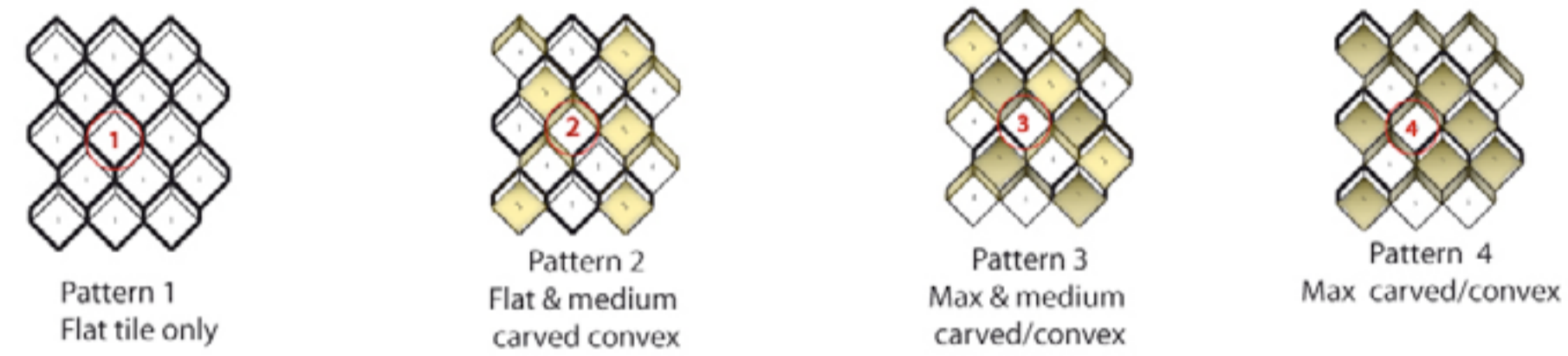
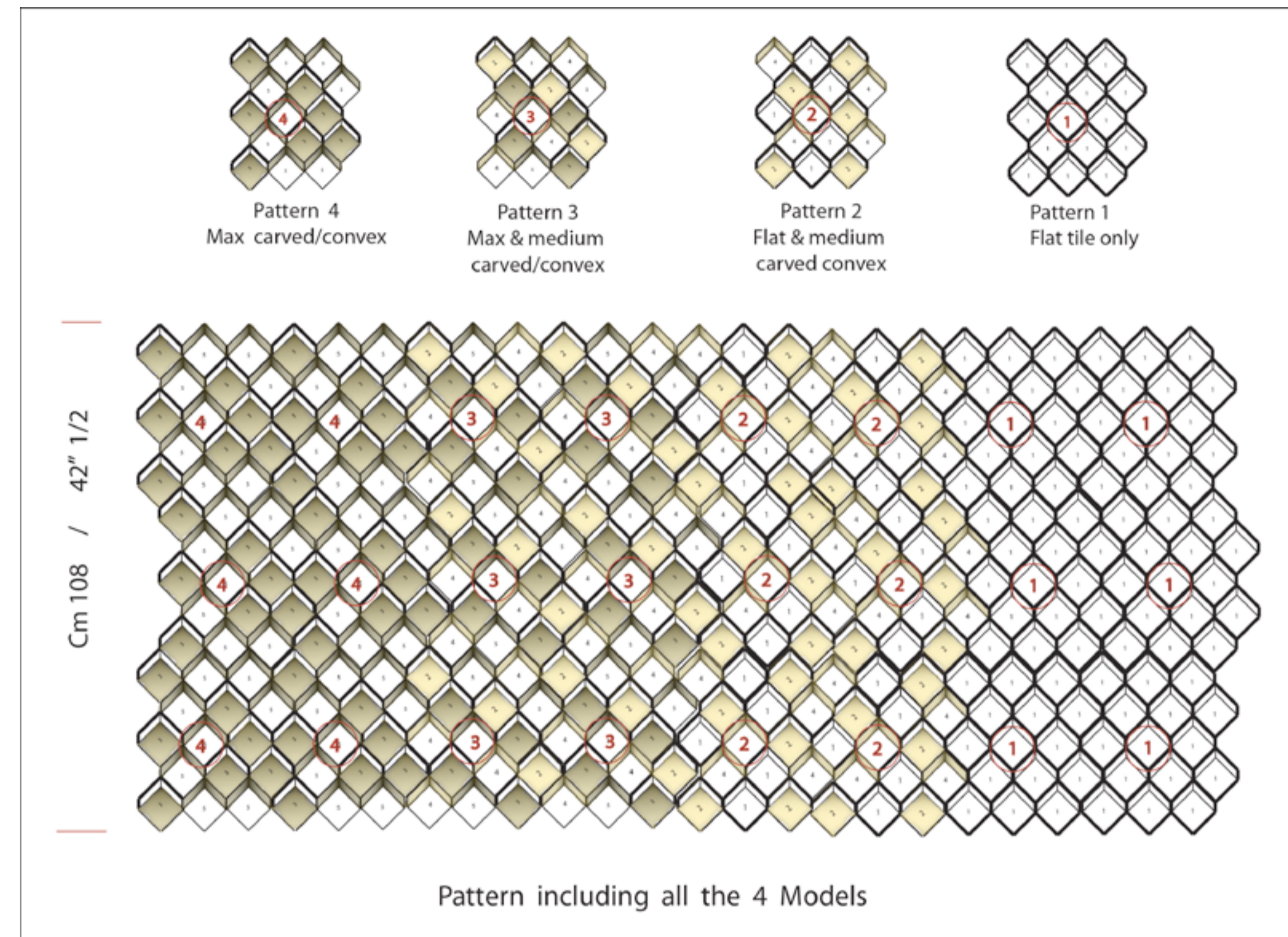

Pattern with Carved & Convex Tiles.

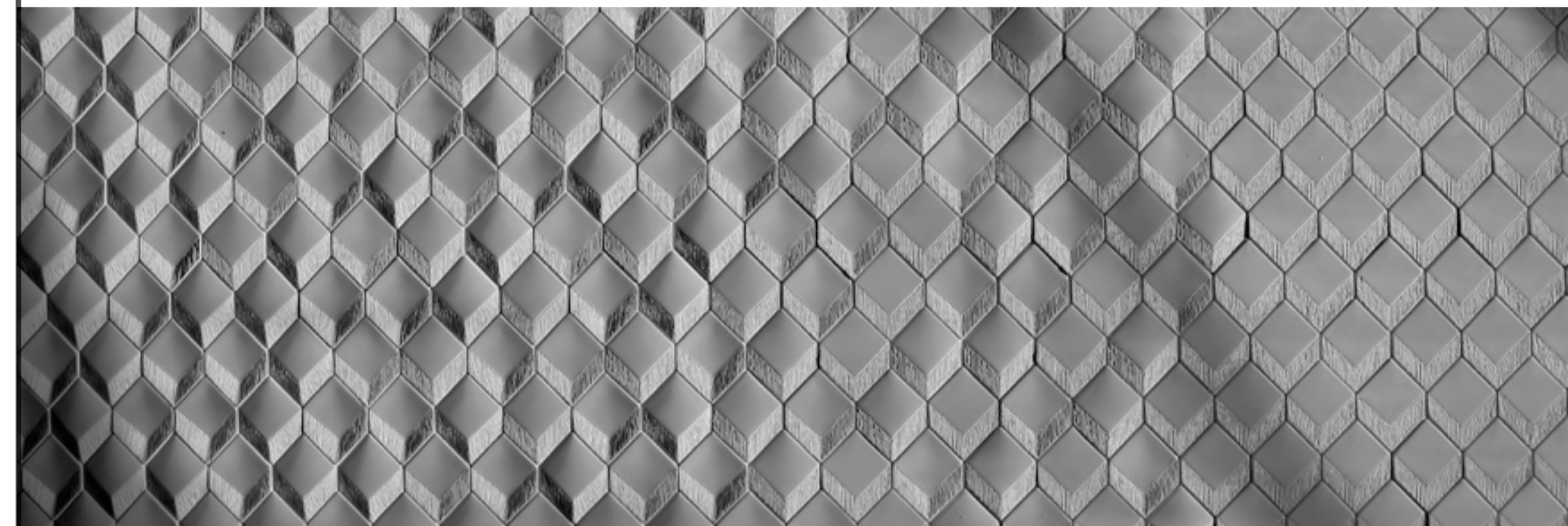

INFINITIVE AESTHETICAL SOLUTION ARE POSSIBLE USING

JUST ONE TO ALL FOUR MODELS AT YOUR PLEASURE.

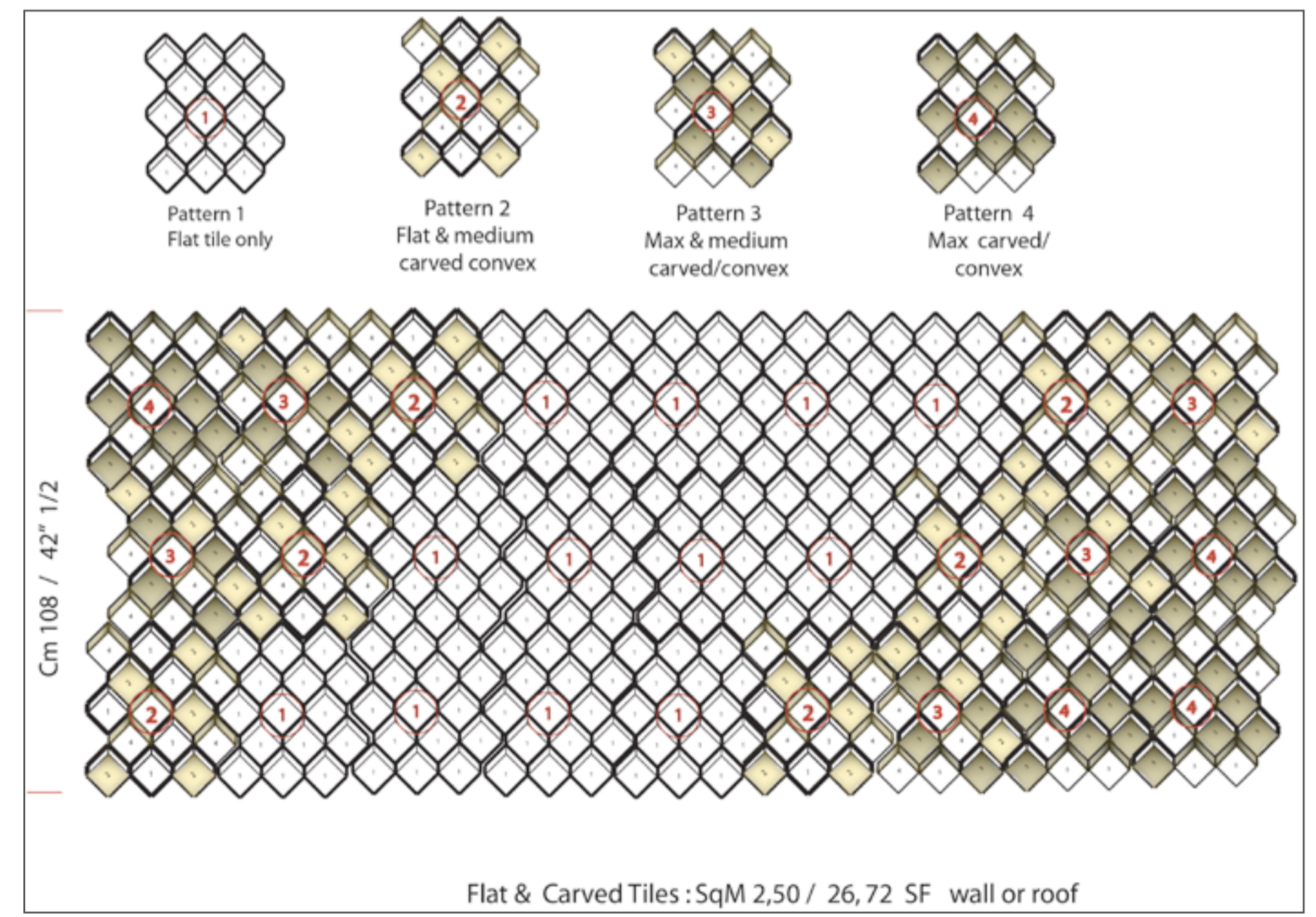
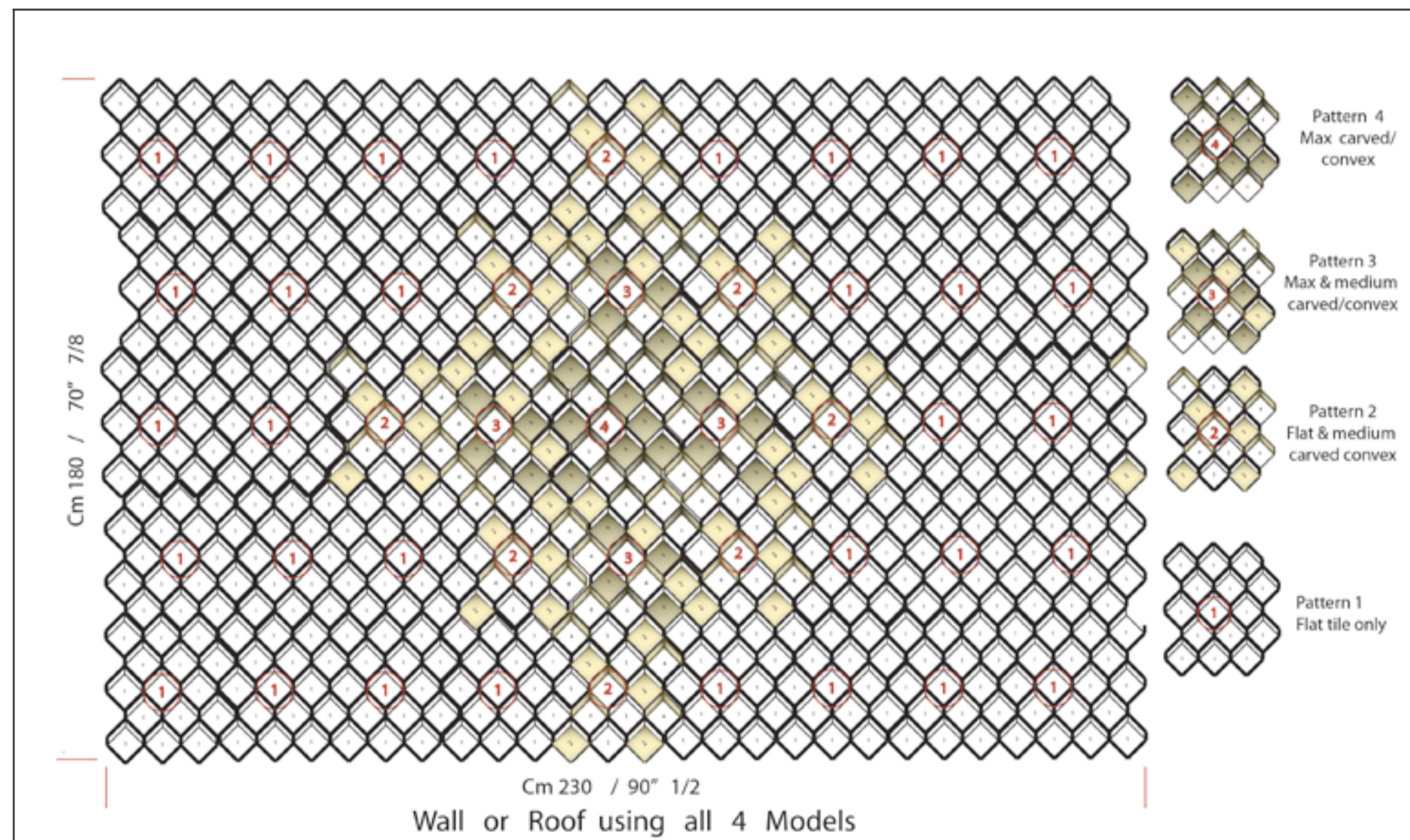
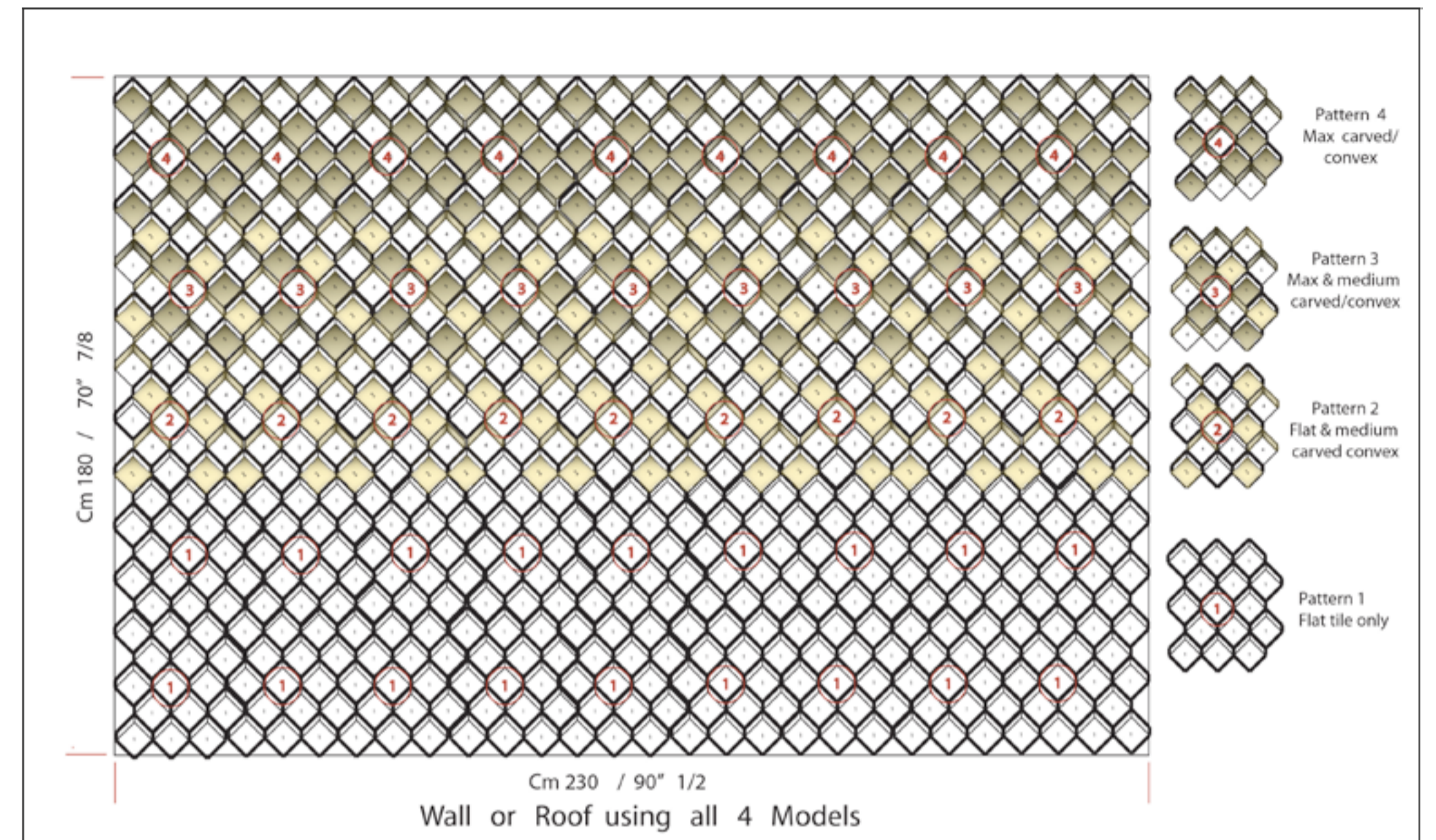
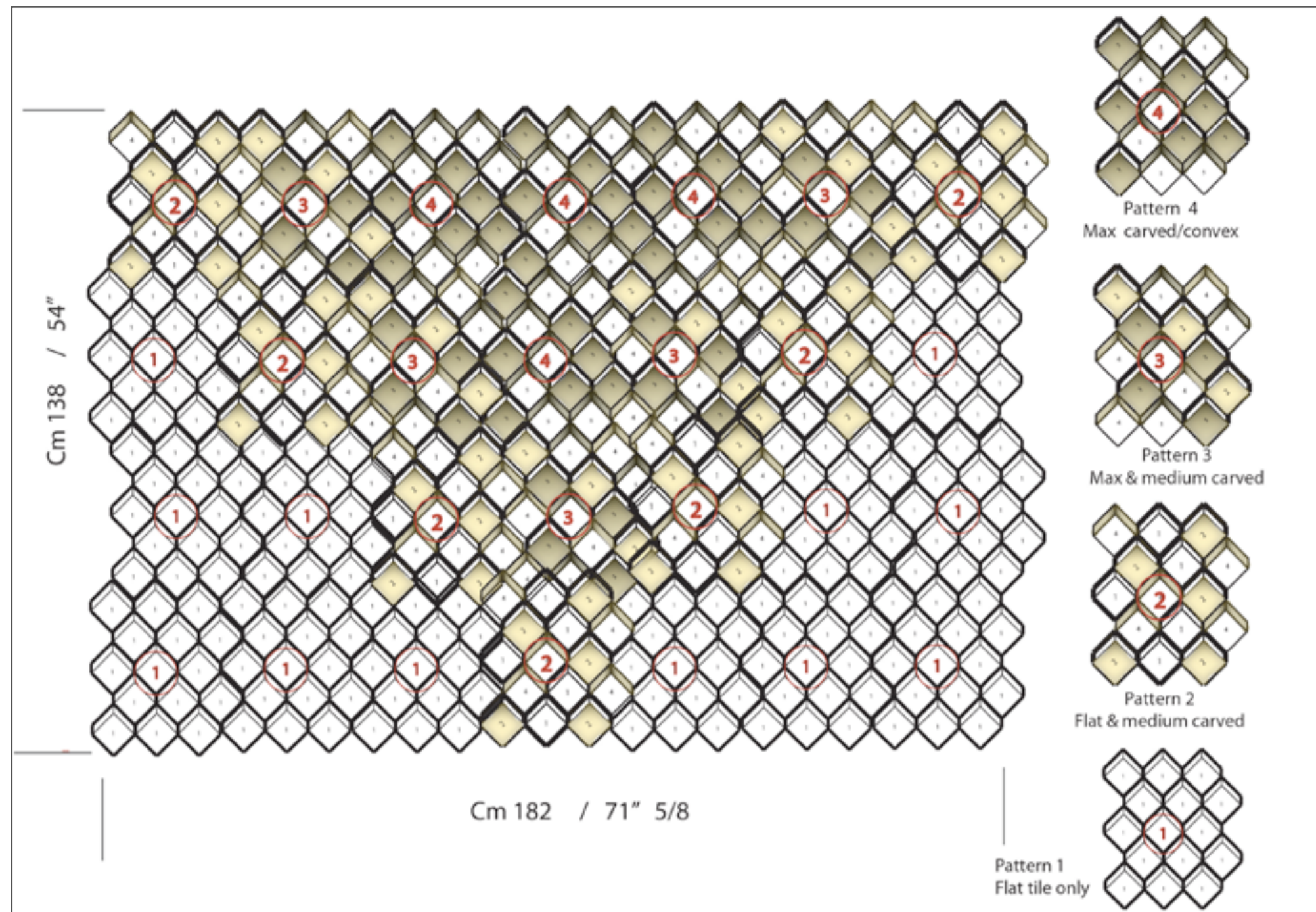

# TRIFACE

LENGHT 6" x DEEP 1" 1/4 FACE WIDTH 1"  
AVAILABLE IN ENGINEERED MARBLE ( NOT AVAILABLE IN GYPSUM)



HOTEL JEN LOBBY AT CHINA WORLD TRADE CENTER BEIJING.  
2017 INTERIOR DESIGN OF THE YEAR AWARD WINNER : INTERNATIONAL PROJECT AT  
THE COMMERCIAL INTERIOR DESIGN CATEGORY.  
SPECIAL THANKS TO STICKMAN STUDIO - DUBAI / HONG KONG.



VERTICAL DISPOSAL WITH DIFFERENT LIGHTING.  
CONCRETE PRODUCTION

© COPYRIGHT BY GIOVANNI BARBIERI

**S** DIMENSION

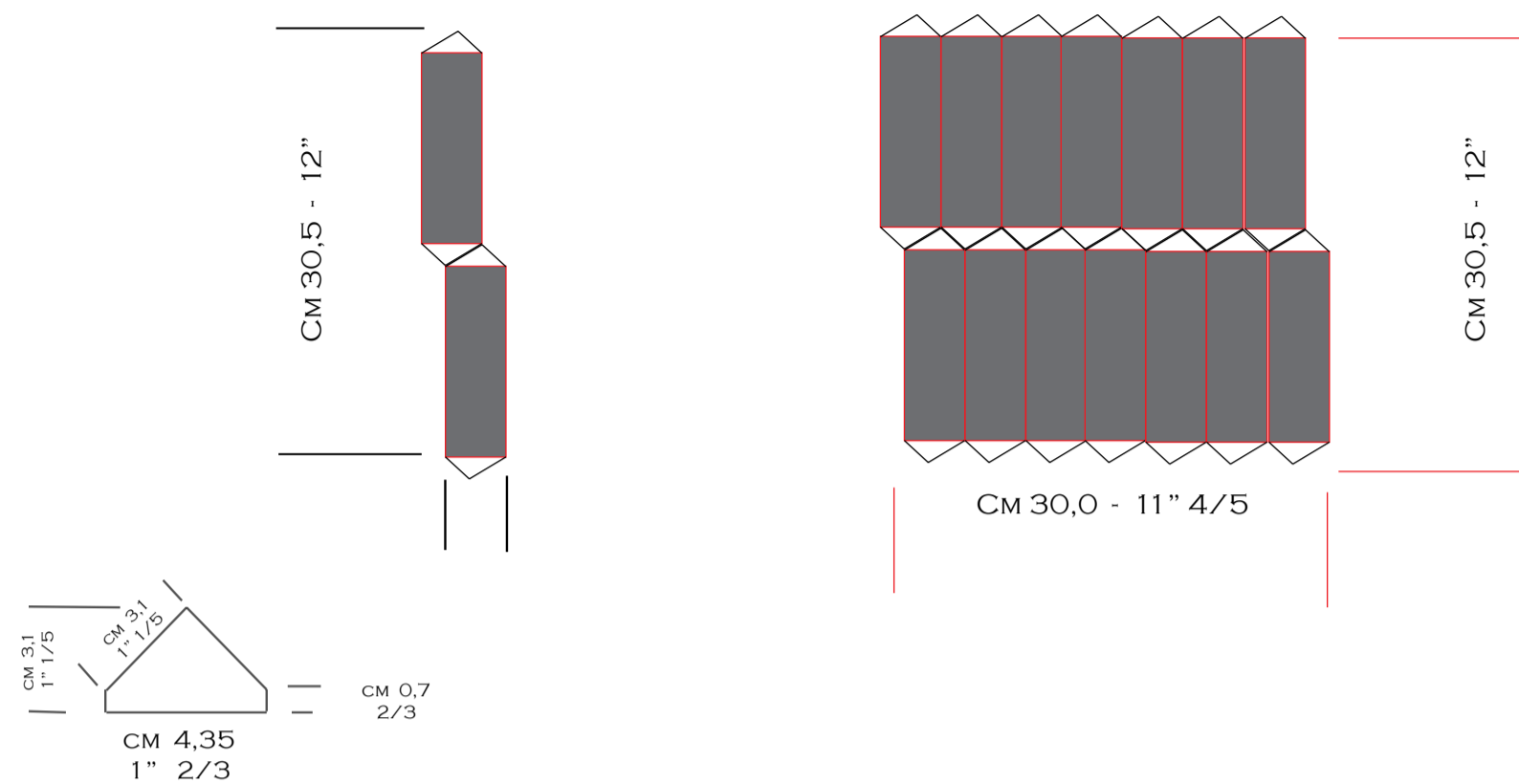

**XL** DIMENSION

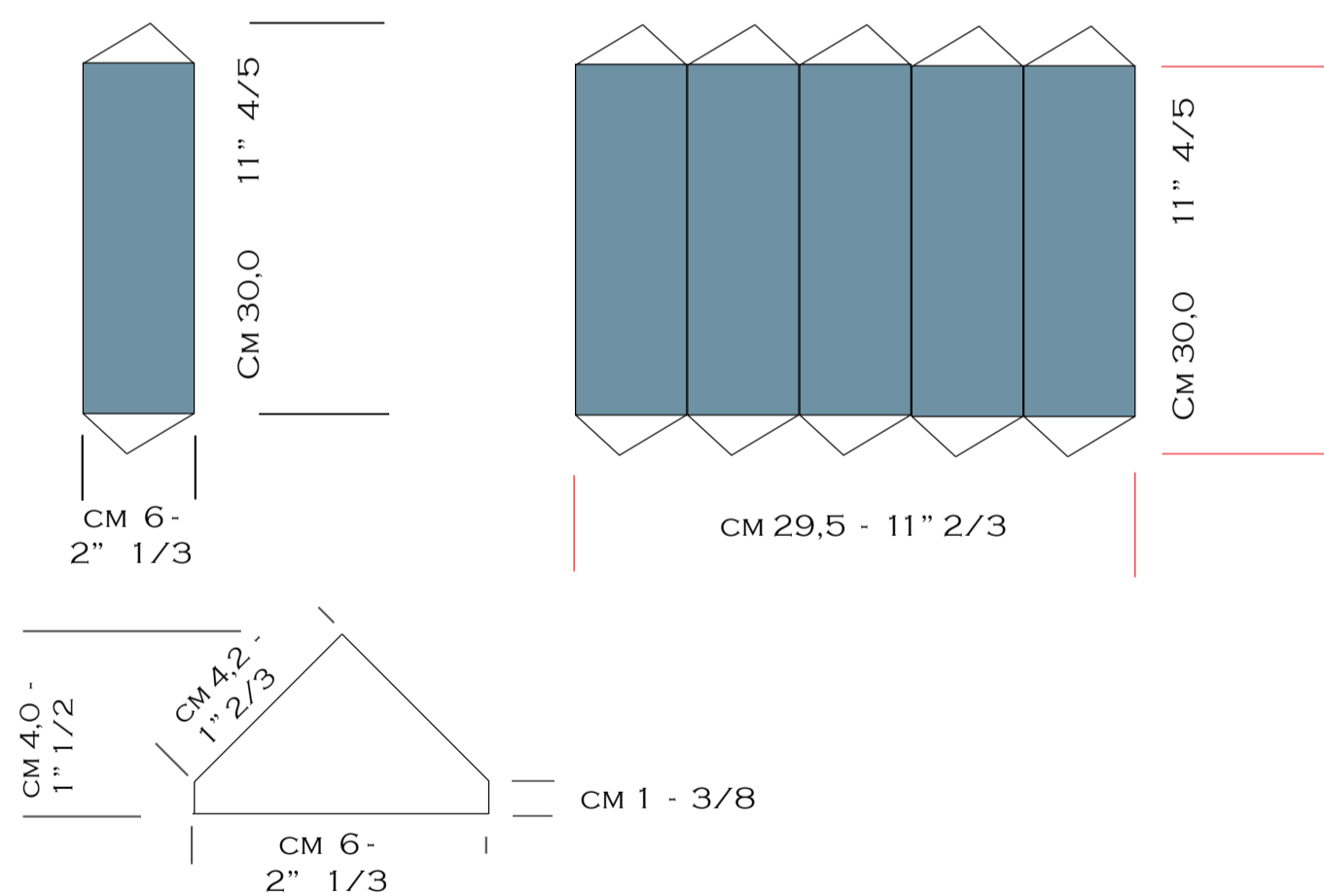

6 COLOUR OPTIONS



**TRIFACE**

LENGHT 6" X DEEP 1" 1/4 FACE WIDTH 1"  
ENGINEERED MARBLE TRAVERTINE REPRODUCTION

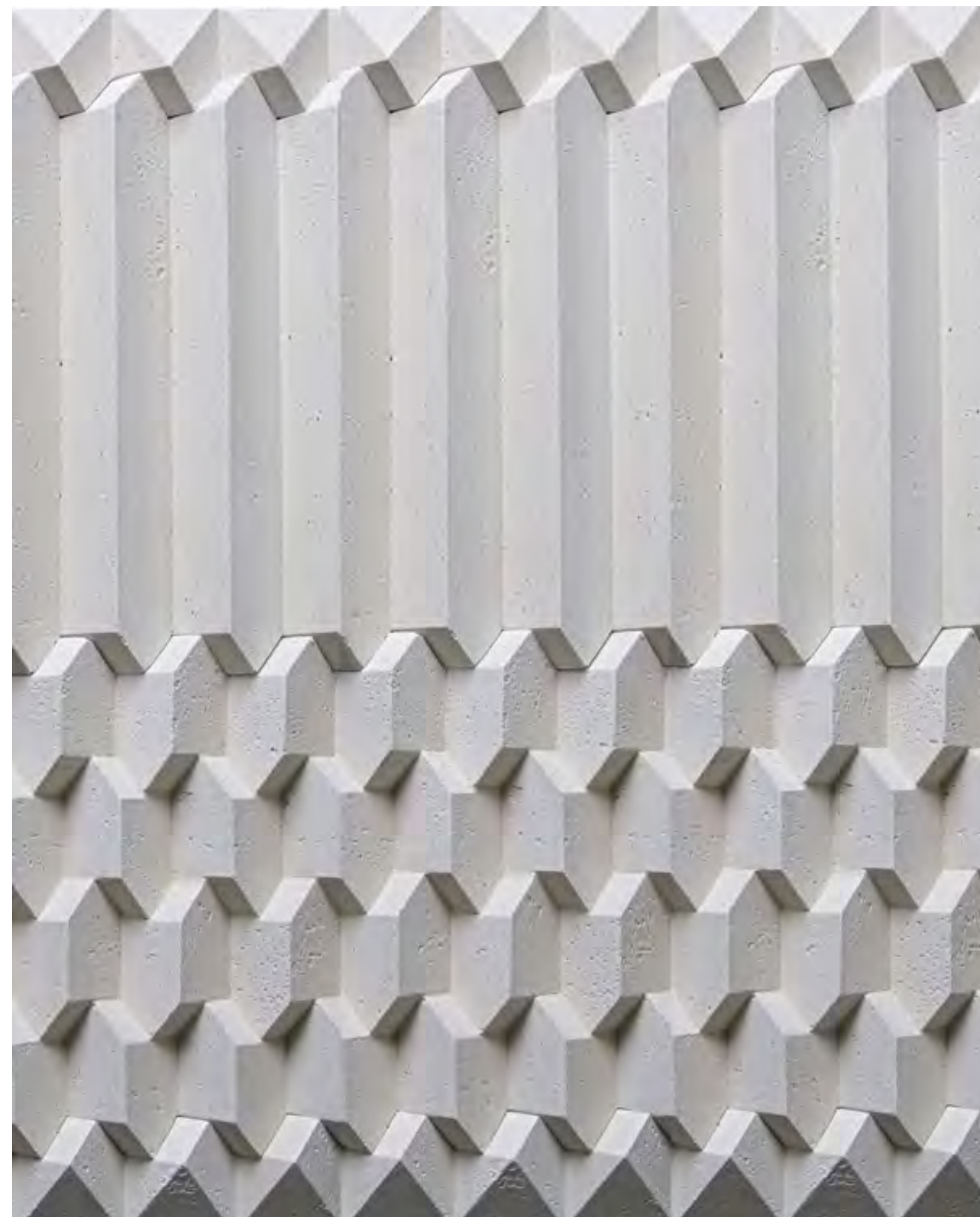

ITEM: A1  
TERMINAL TOP

ITEM : A2  
LINEAR

ITEM: A3  
SQUARED

ITEM A4  
TERMINAL BOTTOM

COLOUR: LIGHT TRAVERTINE  
THE ENGINEERED MARBLE VERSION  
HAVE NO VISIBLE JOINTS

# FLORA

A SINGLE SHAPE CREATING A NEVER REPETITIVE AESTHETICAL RESULT AUTOMATICALLY.  
AVAILABLE IN ENGINEERED MARBLE AND GYPSUM.

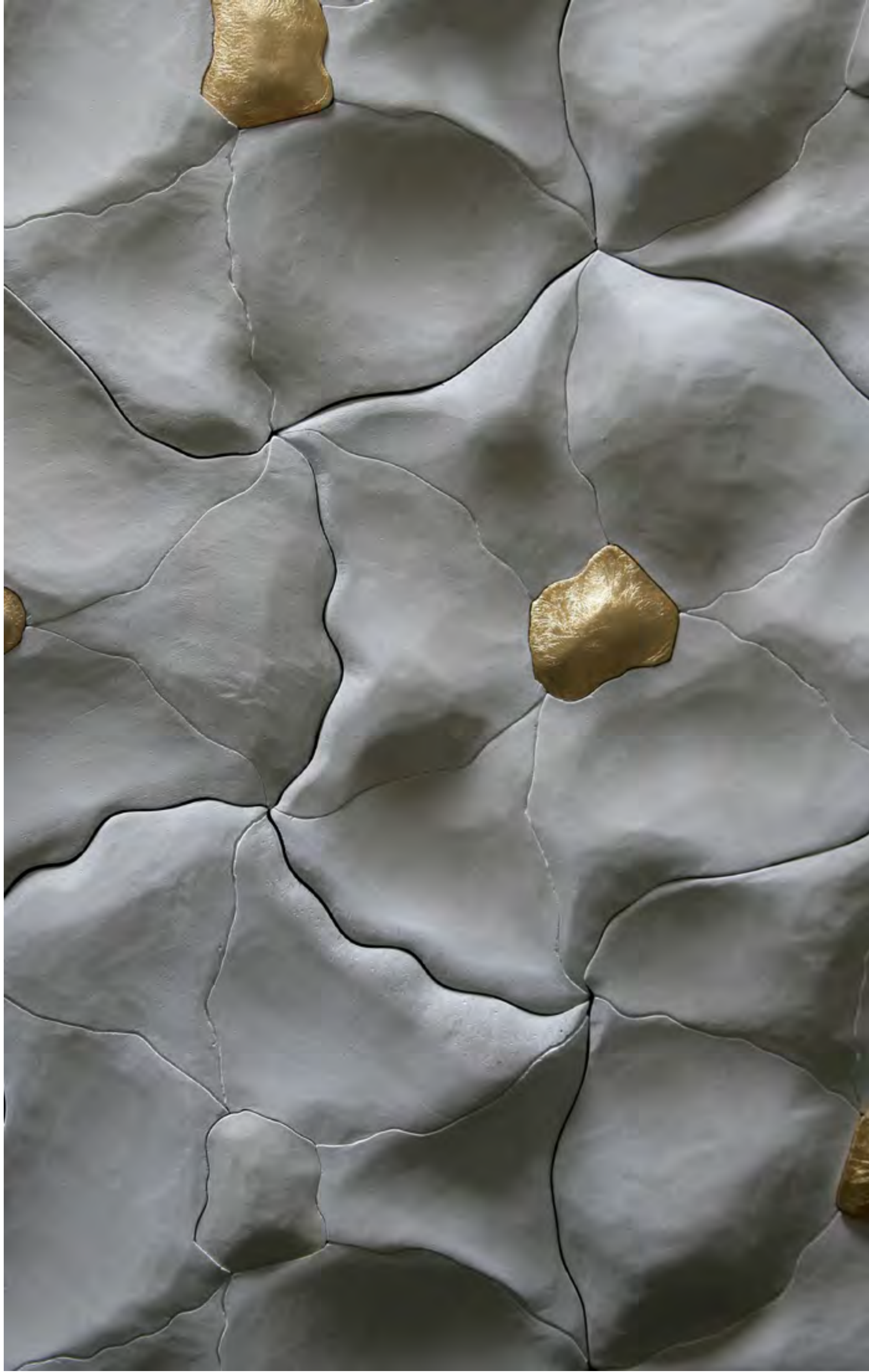

TILES SIZE 1,34 SF / SQ.M 0.125 EACH PIECE.  
THICKNESS FROM 3/8 TO 1" 1/2" ( 10 MM TO 38 MM )

2 DIFFERENT MODELS WITH SIMPLY RANDOMLY INSTALLATION  
OBTAINING A NO REPETITIVE DRAWINGS AND 3D SURFACE.  
SILVER - GOLD LEAF APPLICATION ON CENTER INLAY AVAILABLE UPON REQUEST, ONLY.

## 6 COLOURS OPTIONS



WHITE  
LIMESTONE



BOTTICINO



JASMINE



BROWN

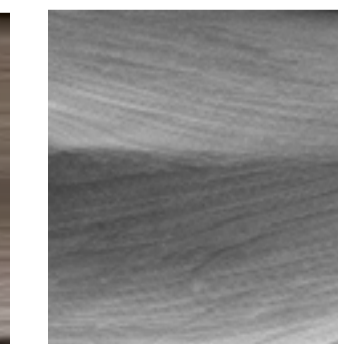

IRON GREY

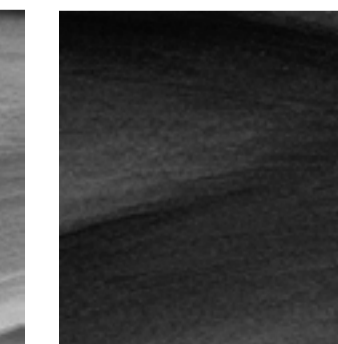

DARK GREY

ENGINEERED MARBLE LABORATORY TEST CERTIFICATES  
AND SETTING INSTRUCTIONS

ALL 6 LABORATORY CERTIFICATE TESTS  
ARE MADE IN USA .  
PLEASE ASK TO OUR REPRESENTATIVE OFFICE  
TO RECEIVE A COPY OR DOWNLOAD THEM  
TOGETHER SETTING INSTRUCTIONS AT  
[WWW.GIOVANNIBARBIERI.COM](http://WWW.GIOVANNIBARBIERI.COM).

# “SOPHISTICATED SIMPLICITY”

“GIOVANNI BARBIERI DEVELOPED A NEW WAY  
TO CREATE WALLS AND FLOOR PATTERNS.

IT IS THE FIRST SERIES PRESENTING A DIFFERENT SHAPE-DRAWINGS RESULT  
BY USING STANDARD PRODUCTION TILES.

WHAT HAS BEEN POSSIBLE THROUGH CUSTOM MADE DESIGN PROJECTS SO FAR,  
IS NOW AVAILABLE THANKS TO THE PRODUCTION OF STANDARD TILES,  
WHICH CAN BE EASILY INSTALLED RANDOMLY  
WITHOUT HAVING REPETITIVE DESIGNS,  
BY VIRTUE OF THIS AVANT-GARDE PROCESS.

THIS IS A NEW CONCEPT TO CREATE INFINITIVE WAYS OF STYLES  
AND MODELS IN 3 VERSIONS: MOSAIC, TILES, 3D WALLS.

THESE FIRST EXAMPLES ARE **FLOWAYS** AND **SQUARED** COLLECTIONS,

A NEW AESTHETICAL RESULTS THAT ARE THE FIRST PART OF THE LATEST  
“**SOPHISTICATED SIMPLICITY**” SERIES



## **“FLOWAYS”**

IS THE FIRST COLLECTION PRESENTING  
A DIFFERENT SHAPE-DRAWINGS INSTALLATION RESULT  
BY USING STANDARD PRODUCTION TILES.

STANDARD PRODUCTION TILES NOW CREATE  
ALWAYS DIFFERENT DRAWINGS  
AVOIDING THE “REPETITIVE EFFECT”.

**“FLOWAYS COLLECTION”**  
IS AVAILABLE IN WATERJET MOSAIC,  
TILE AND 3D WALL PATTERNS.

# FLOWAYS

TILE PATTERN DRAWING LAY OUT.  
SIMPLY RANDOMLY INSTALLATION.

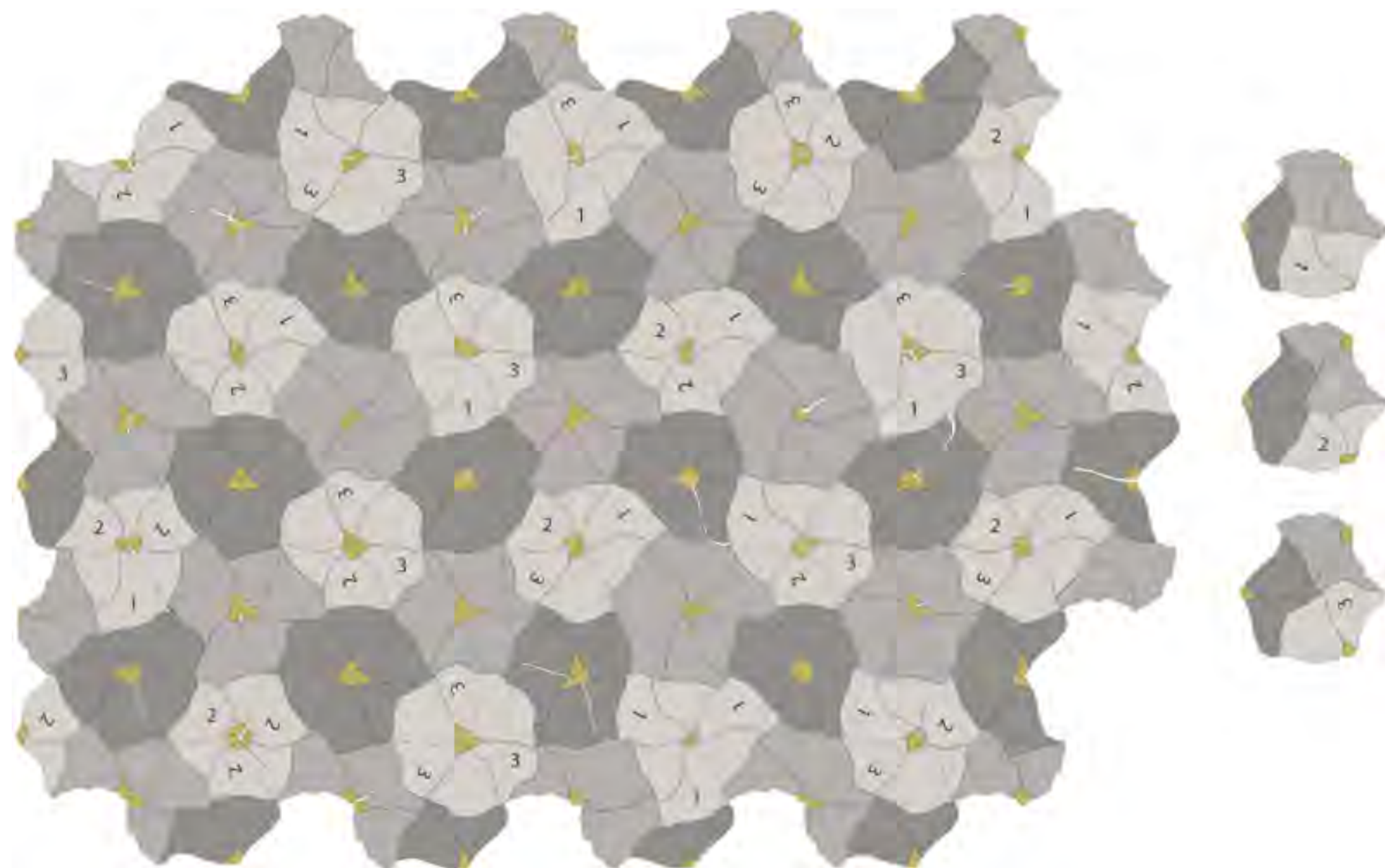

AVAILABLE IN MOST POPULAR NATURAL STONE.  
COMBINED WITH LIGHT BEIGE, GREY, KHAKI HANDMADE TERRACOTTA

CENTER INLAY WOULD BE IN 6 DIFFERENT MURANO GLASS COLOUR OPTION PLUS SILVER AND GOLD





# FLOWAYS TILES

WATERJET CUT TILES ,  
LIGHT BEIGE TERRACOTTA, BIANCO ANTICO AND  
JERUSALEM GOLD MARBLE WITH  
GOLD MURANO GLASS.  
SIMPLY RANDOM INSTALLATION.



1



2



3

# FLOWAYS MOSAIC

WATERJET CUT, ON NET.

LAY-OUT DRAWING FOR SIMPLY RANDOMLY INSTALLATION.



BIANCO CARRARA  
& BARDIGLIO  
IMPERIALE.

© COPYRIGHT BY GIOVANNI BARBIERI AUGUST 2017

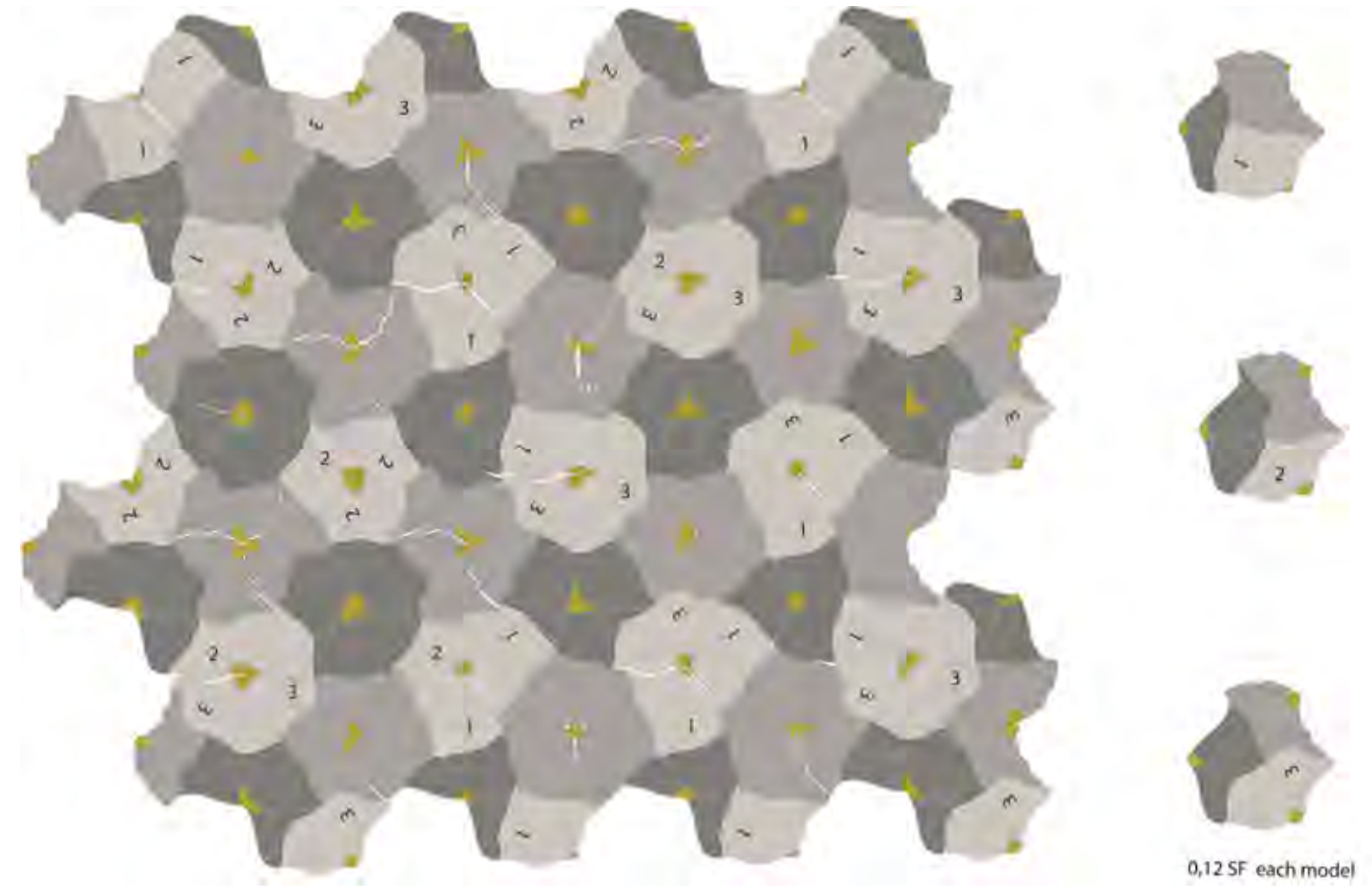

0,12 SF each model

AVAILABLE IN MOST POPULAR NATURAL STONE  
AND  
6 ENGINEERED MARBLE/CONCRETE COLOUR OPTIONS



CENTER INLAY WOULD BE IN 6 DIFFERENT MURANO GLASS COLOURS ALSO.

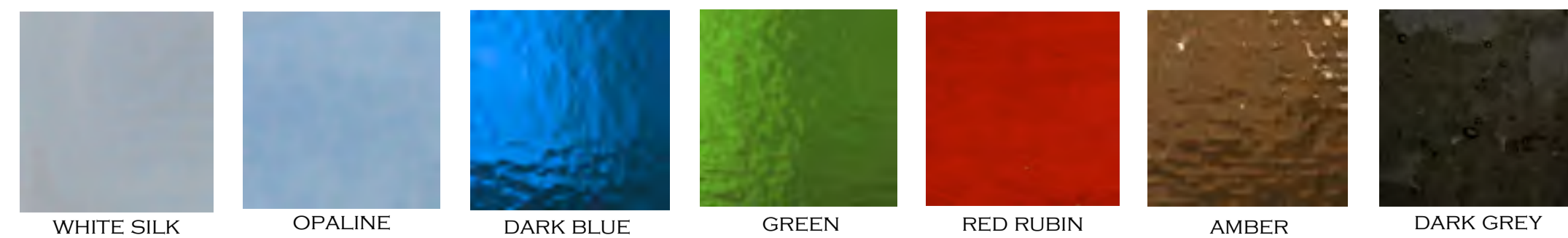

# FLOWAYS 3D

AVAILABLE IN ENGINEERED MARBLE, CERAMIC AND CONCRETE



0,68 SF PER EACH TILE  
THICKNESS FROM 3/8 TO 2"  
CM 1,0 TO 5,0



© COPYRIGHT BY GIOVANNI BARBIERI AUGUST 2017

## “SQUARED”

THIS PATTERN OBTAINING  
SQUARE AND-OR RANDOM PATTERN TILES  
THAT CAN BE INSTALLED TOGETHER.

“**SQUARED** COLLECTION”  
IS AVAILABLE IN WATERJET MOSAIC,  
TILE AND 3D WALL PATTERNS.

THIS PATTERN CAN BE USED FOR ANY APPLICATION USE:

- EXTERIOR FLOOR IN LARGE SCALE NATURAL STONE.
- INTERIOR FLOOR TILES
- MOSAIC FOR FLOOR AND WALL IN WATERJET CUT NATURAL STONE,  
ENGINEERED MARBLE - CONCRETE - CERAMIC TILES FOR KITCHEN BACK-  
SPLASH AND BATHROOM, SPA AND HUMIDITY AREA.

WE WILL BE HAPPY TO HELP YOU DESIGN AND PRODUCE YOUR PROJECT  
IN THE BEST WAY YOU COULD DESIRE.

# SQUARED

TILE PATTERN INSTALLATION WITH INFINITE OPTIONS.  
THE TRIANGLES INLAYS HELP QUICK-EASY INSTALLATION  
AND DETERMINE LARGE AND SMALL JOINTS  
IN ALTERNATIVE WE APPLY 3 DIFFERENT TEXTURES OR NUANCES  
ON EACH PATTERN EXCLUDING TRIANGLES

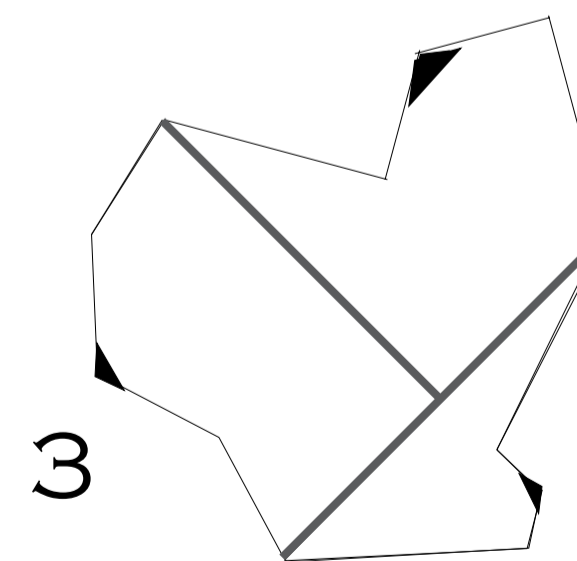
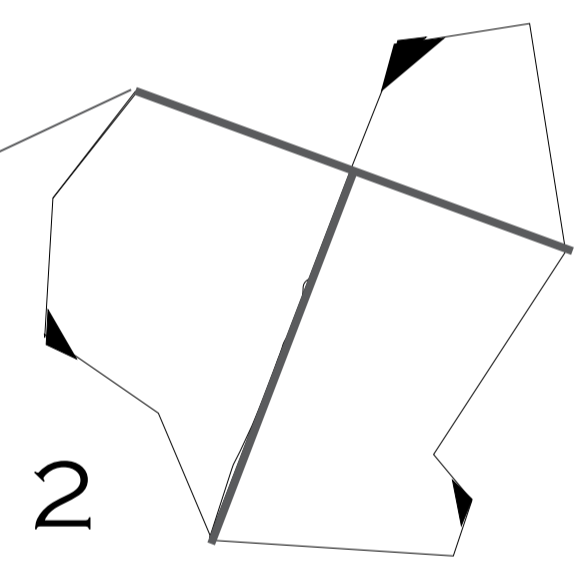
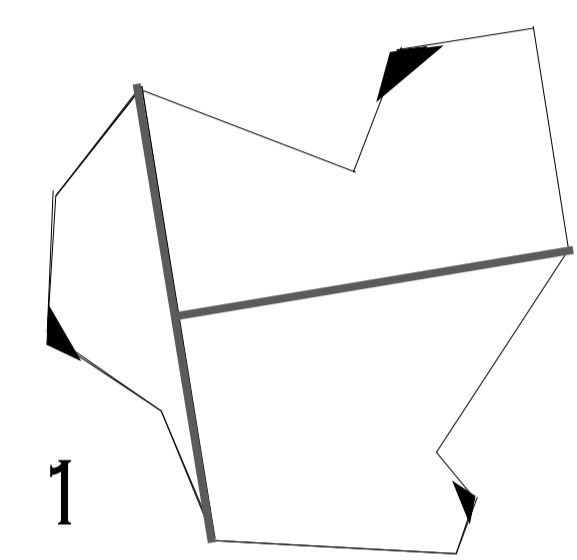
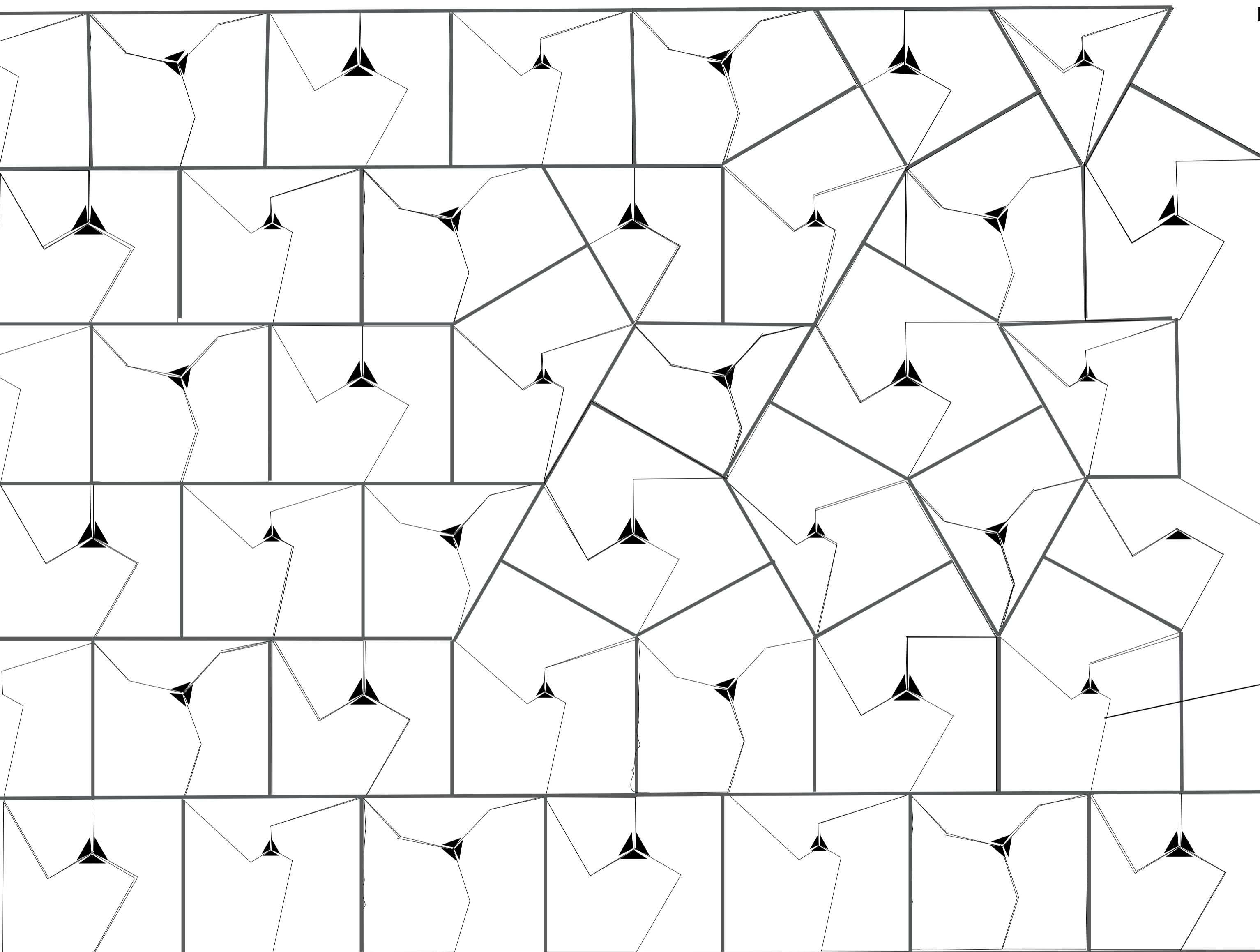

LARGE JOINTS  
3 MM / 1/8

SMALL JOINTS  
0-1 MM / 1/16

SqM 0.093 / 1,00 SF  
PER EACH SINGLE MODEL



# SQUARED

WATERJET CUT TILES,  
ANY COLORWAYS, TEXTURES  
VARIEGATED OR MONOCHROMATIC  
FIT TO SIZE PROPORTION .



0,093 SqM / 1,0 SF  
EACH SINGLE MODEL



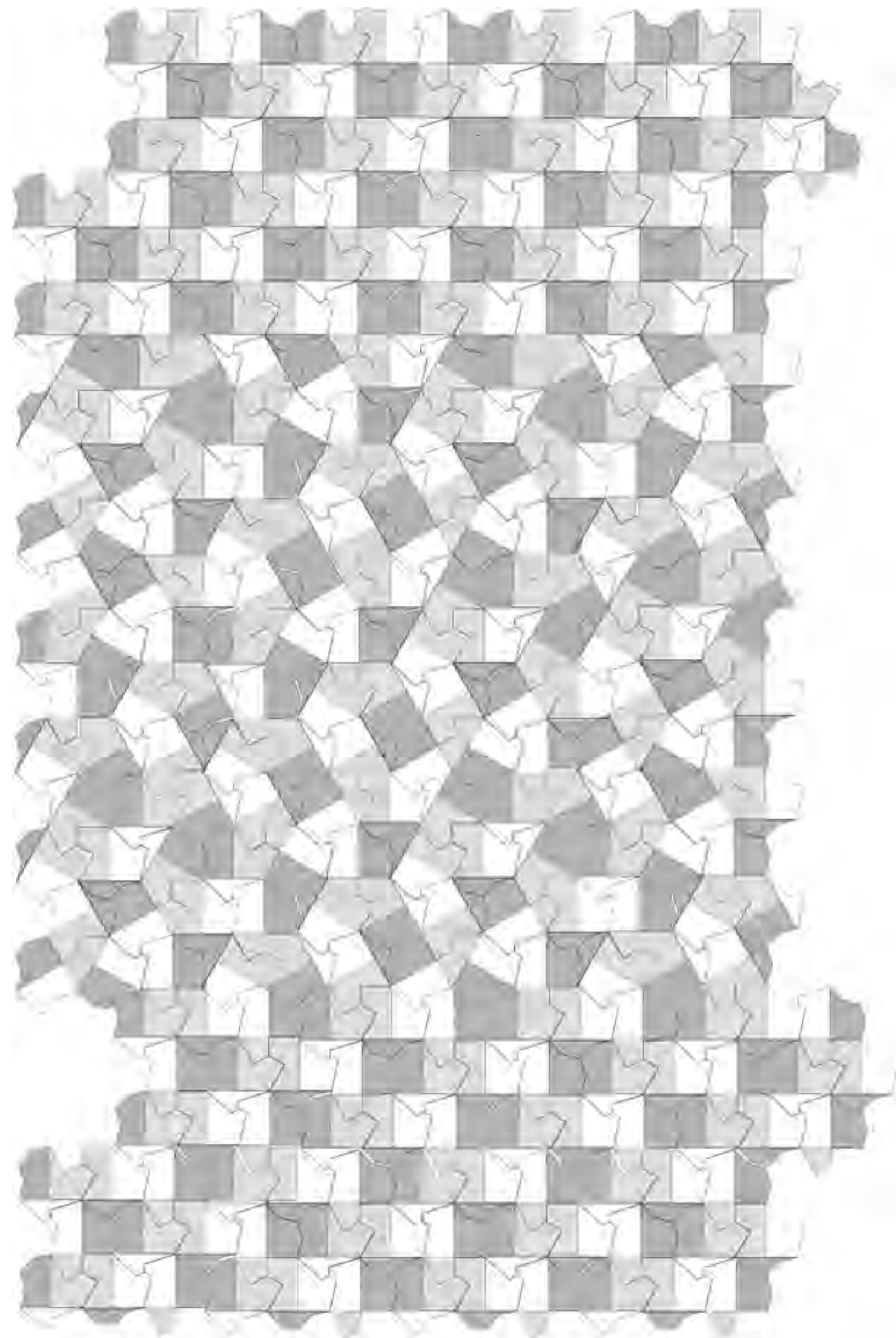

MADE BY SAME PERIMETRAL SHAPE 3 MODELS  
OBTAIN 3 DIFFERENT MESH MOUNTED PATTERN  
THAT CAN BE ASSIMILATED EACH OTHER CREATING  
MANY DIFFERENT UNIQUE AESTHETICAL RESULT  
AT YOUR PLEASURE.

SQM 0.012 / 0,116 SF PER EACH SINGLE MODEL

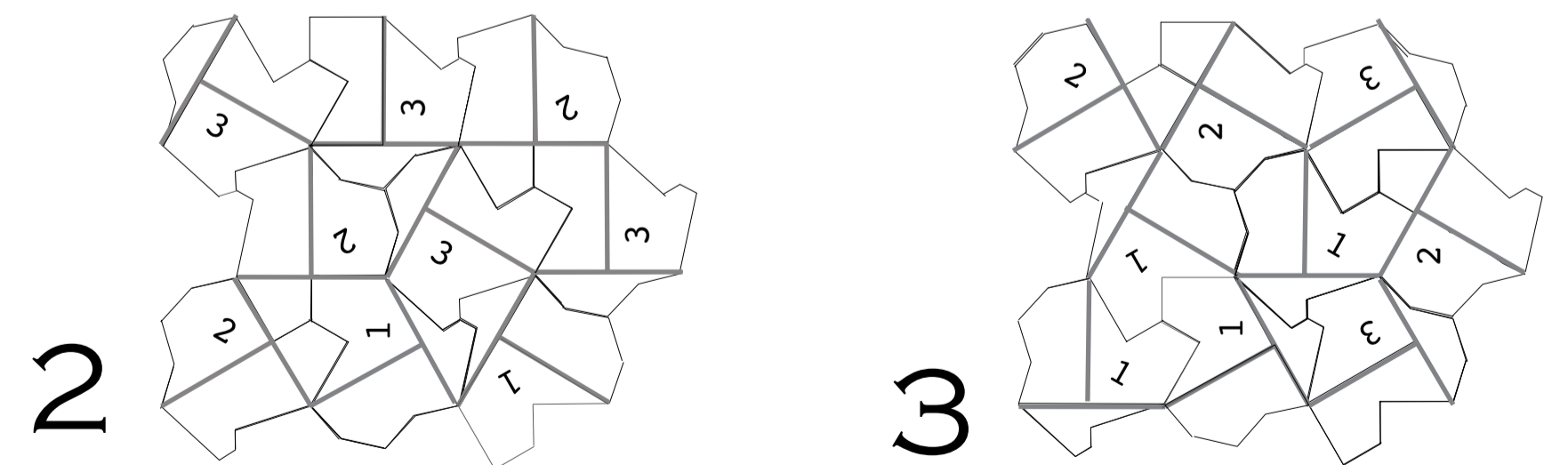
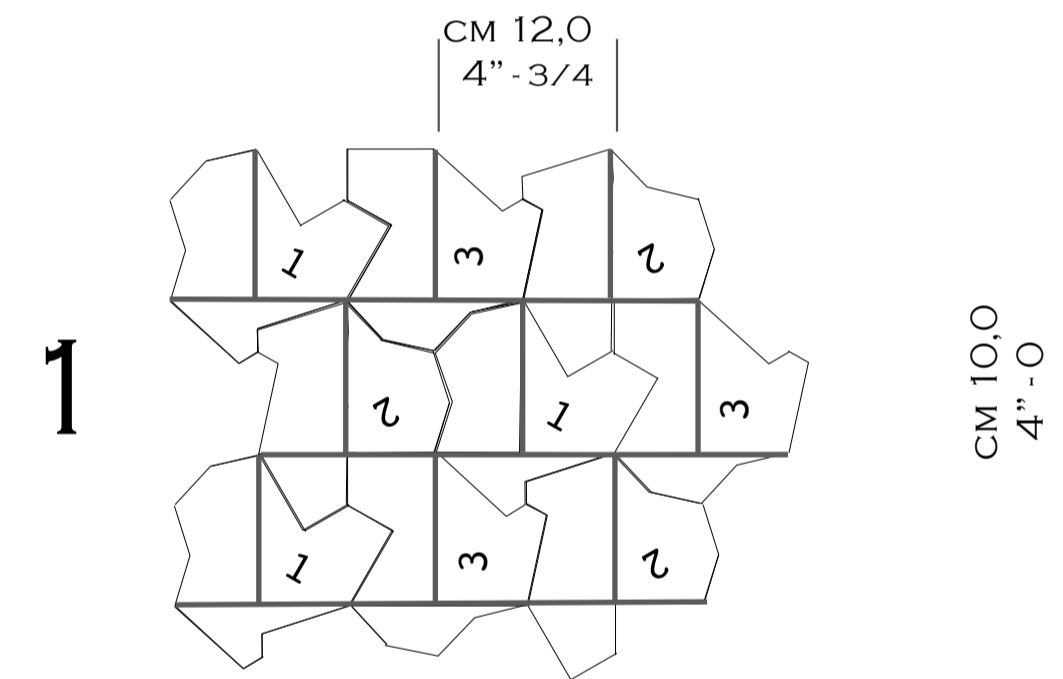

SQM 0.11 / 1,16 SF PER EACH SHEET

# SQUARED MOSAICS

INSTALLATION OPTIONS

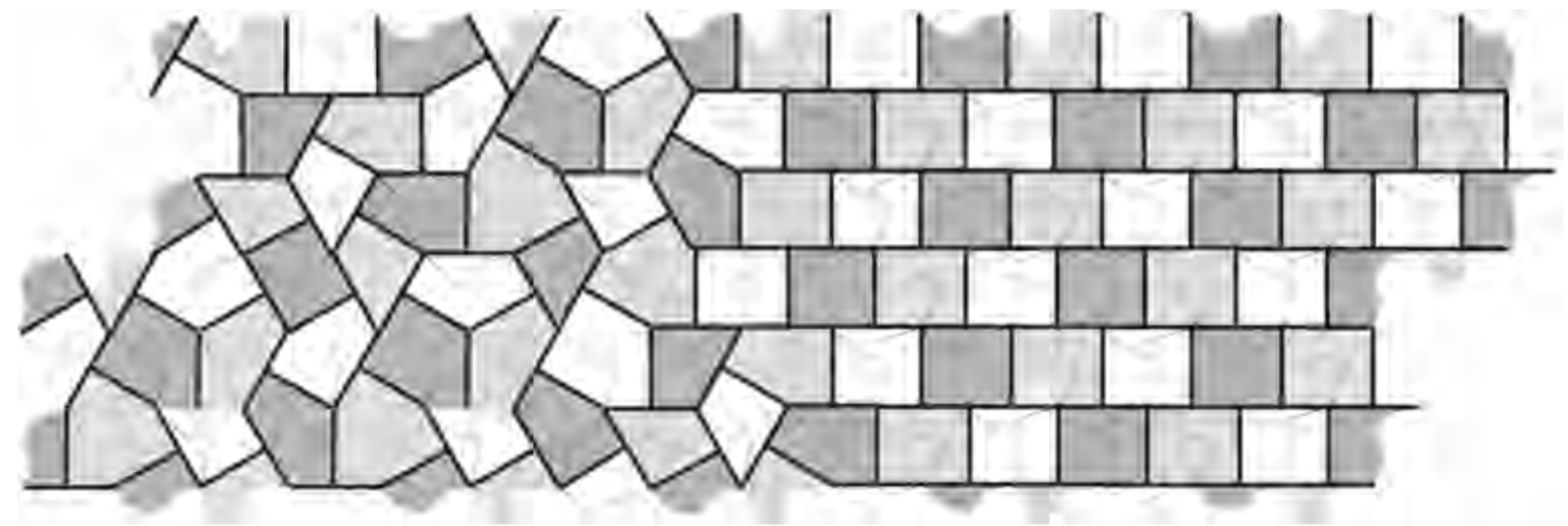
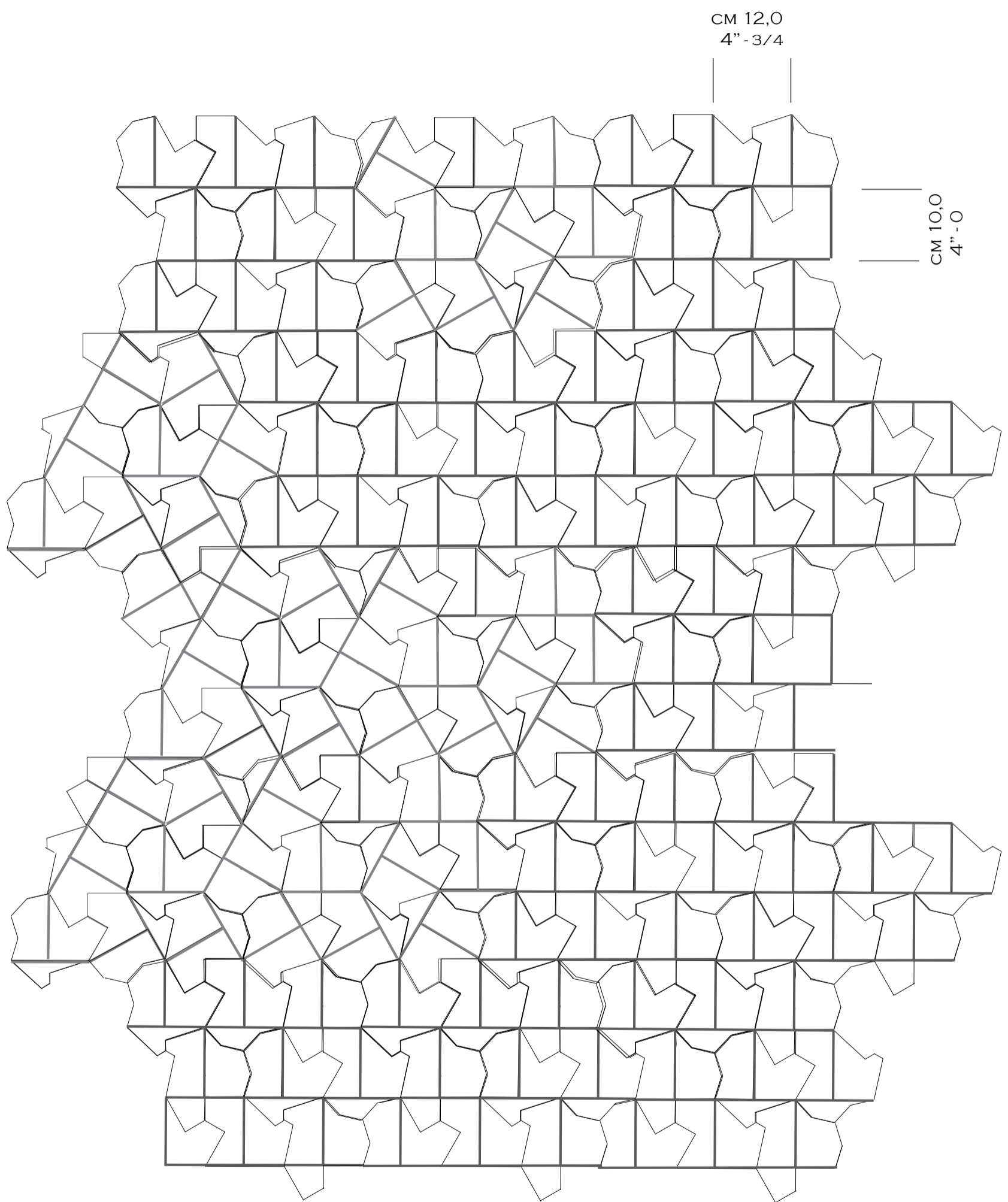

CM 157 / 157"

CM 61 / 24"

## 6 ENGINEERED MARBLE/CONCRETE COLOURS OPTION

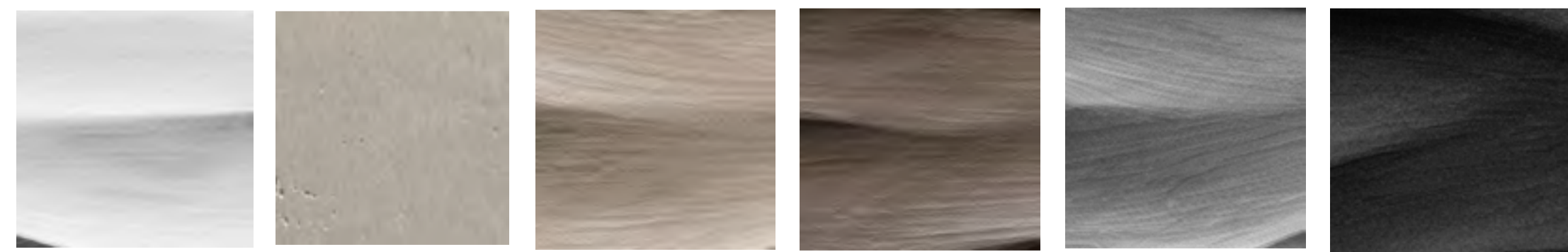

WHITE LIMESTONE    BOTTICINO    JASMINE    BROWN    IRON GREY    DARK GREY

# SQUARED MOSAIC



HANDMADE ANTIQUED BLACK TERRACOTTA



CARRARA, BIANCO ANTICO, CALACATTA MARBLE.



# SQUARED 3D

HAVING SATINATED, HIGH HONED AND POLISHED SURFACE  
ANY COLOURWAYS AVAILABLE IN CONCRETE, CERAMIC, PORCELAIN.

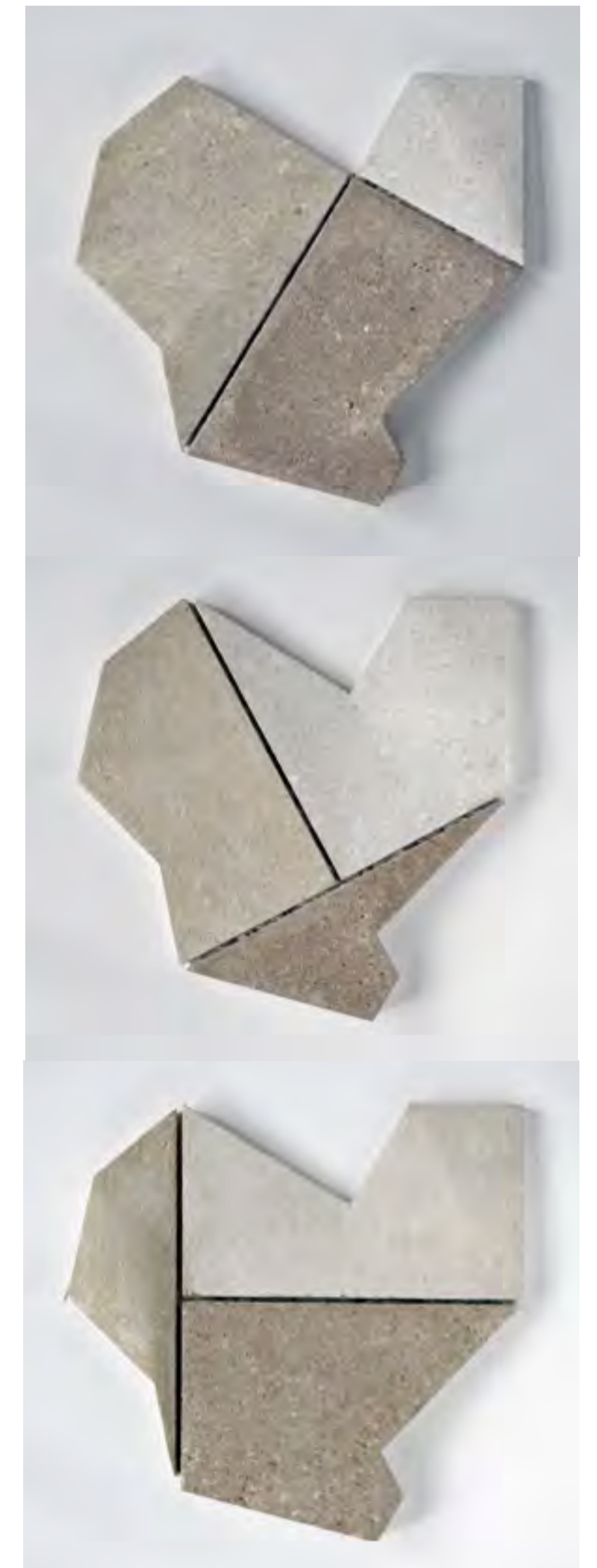

1,38 SF - 0,13 SQM PER EACH MODEL

THICKNESS FROM 3/8 TO 2" 1/3  
CM 1,0 TO 6,0

# PATTERNS



DARK GREY & OPALINE MURANO GLASS INLAYS

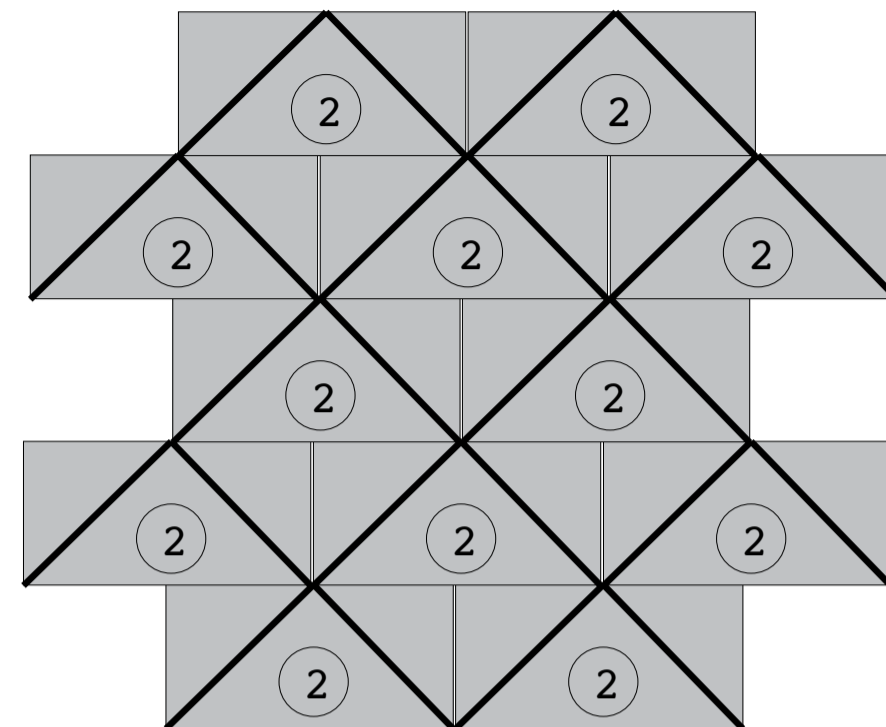

PATTERN "A"



JASMINE & AMBER MURANO GLASS INLAYS.

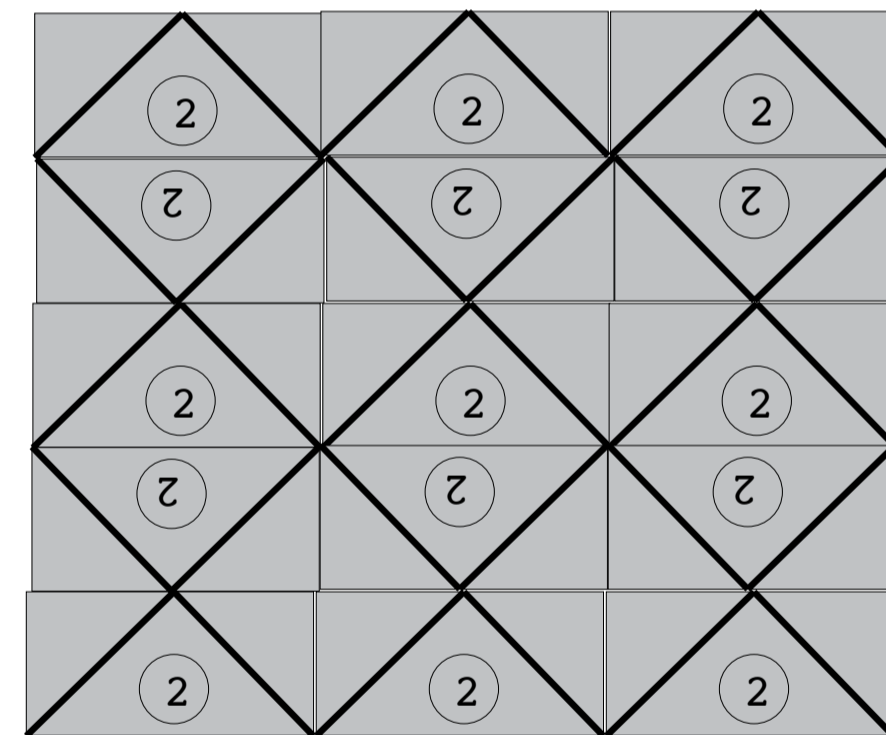

PATTERN "B"

# DRAFT COLLECTION

CONCRETE-ENGINEERED MARBLE WITH CERAMIC OR MURANO GLASS INLAYS.  
 INFINITIVE PATTERNS/INSTALLATION SOLUTIONS.  
 CERAMIC AND MURANO GLASS INLAYS ARE SUPPLIED SEPARATELY,  
 CUSTOM MADE COLOUR OPTIONS AVAILABLE.

## 3 MODELS

1 FIELD TILE

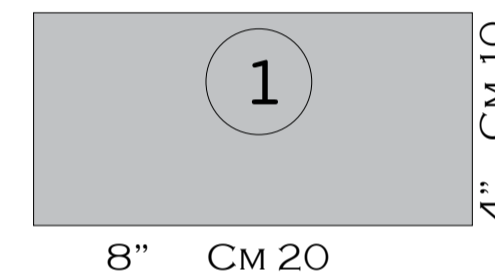

2 FISHBONE TILE

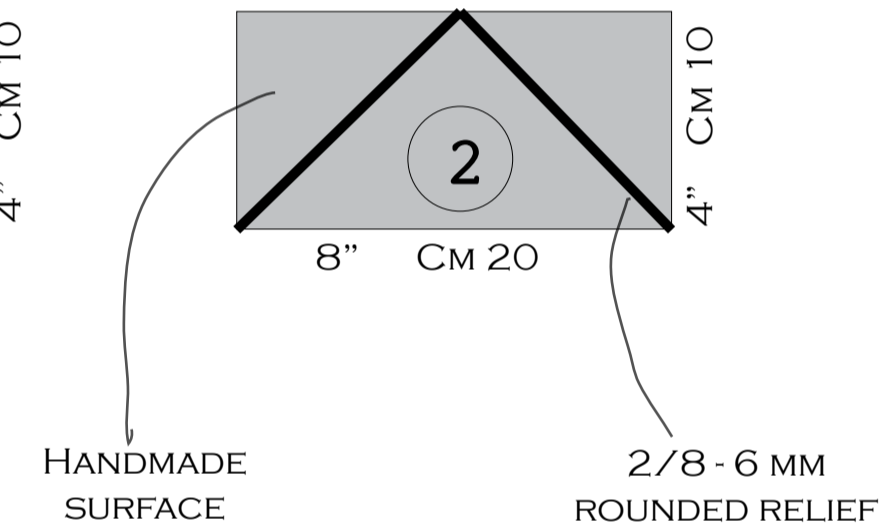

3 LISTELLO TILE



## 6 ENGINEERED MARBLE/CONCRETE COLOURS OPTION



## INLAYS "LISTELLO" WOULD BE IN 6 DIFFERENT MURANO GLASS COLOURS OPTION.

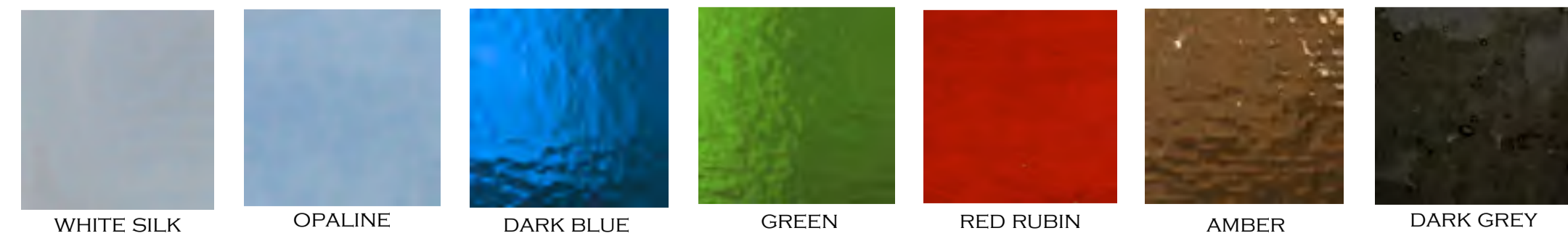

# PATTERNS



JASMINE & WHITE SILK MURANO GLASS INLAYS

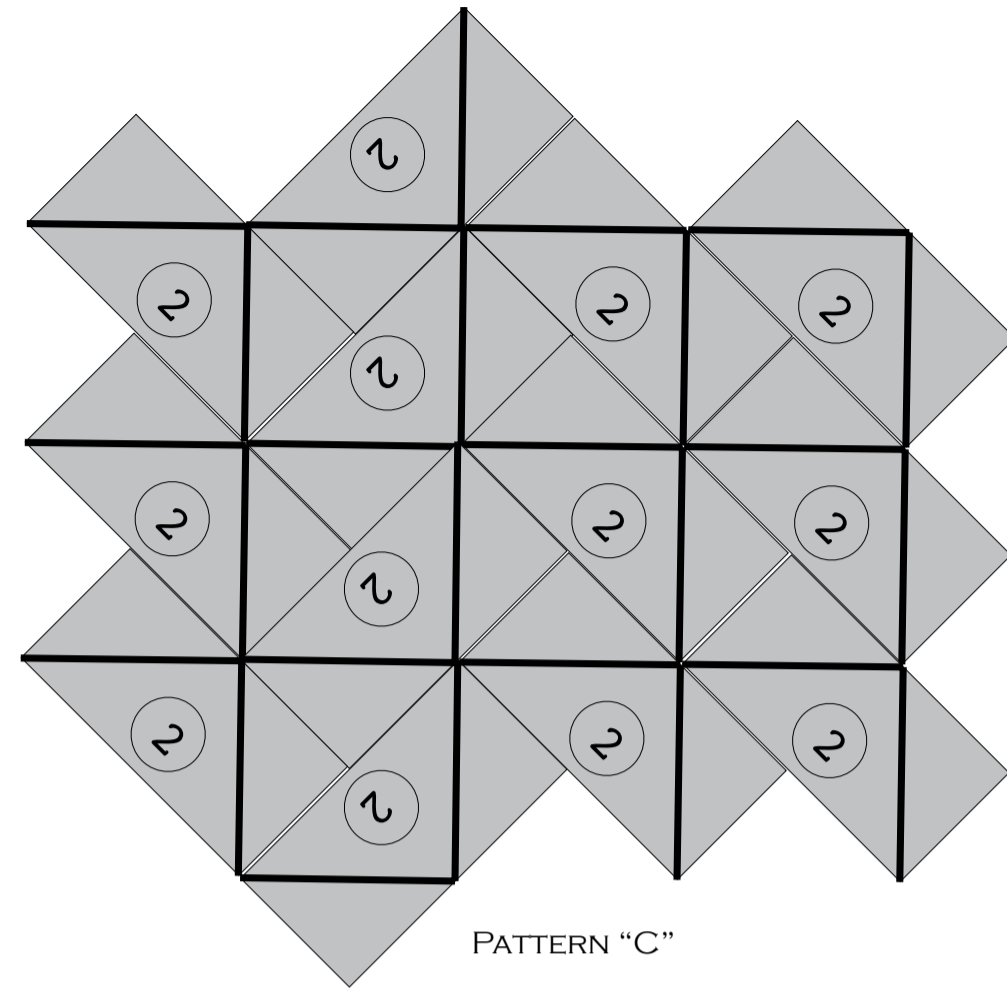

PATTERN "C"

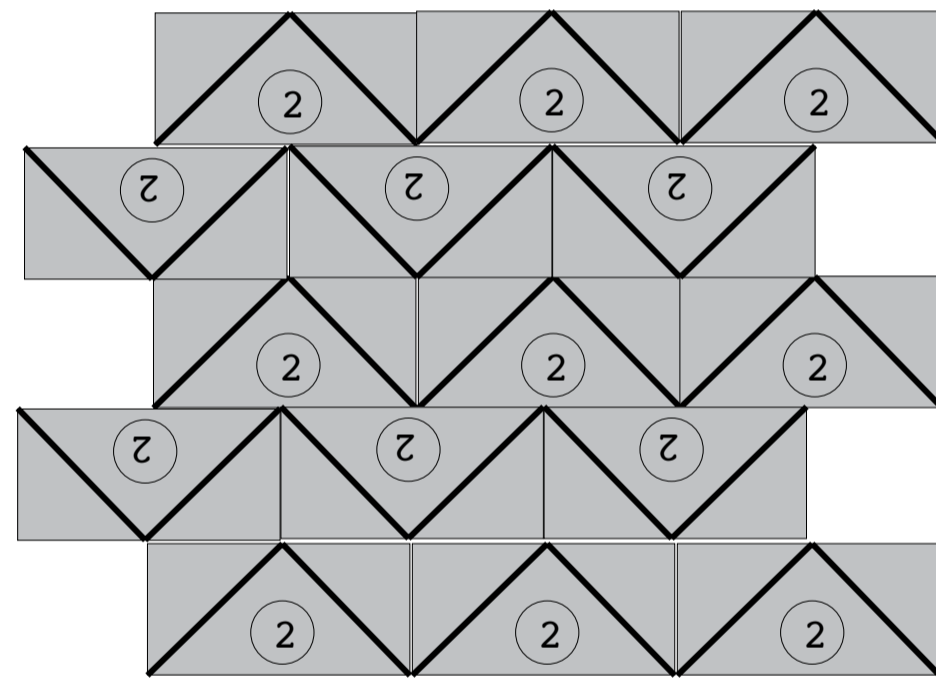

PATTERN "D"

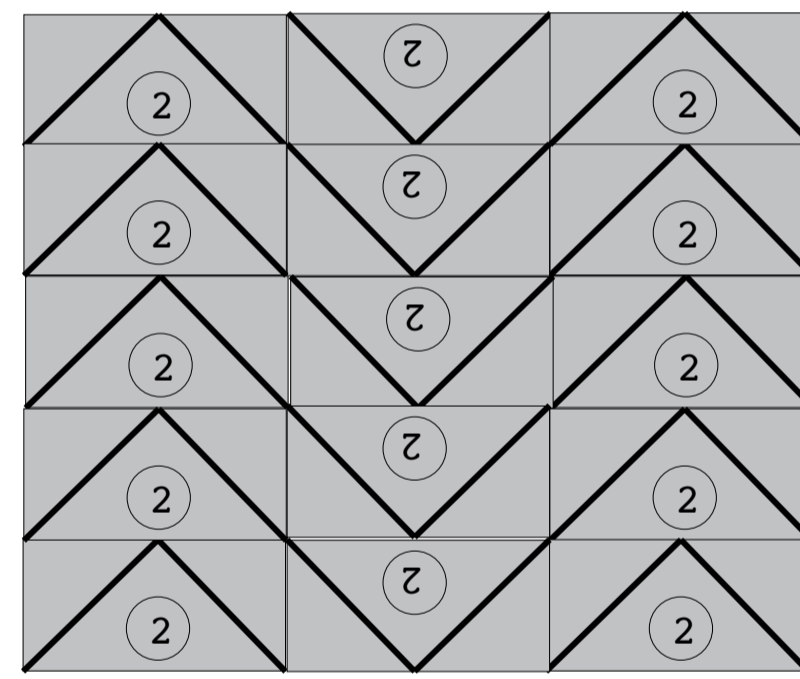

PATTERN "E"

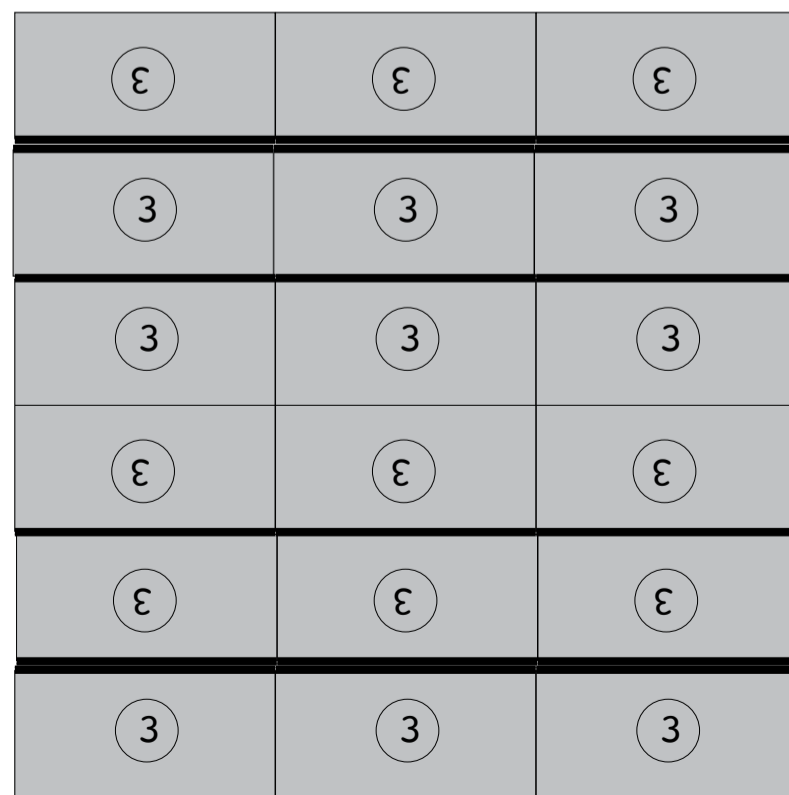

PATTERN "F"

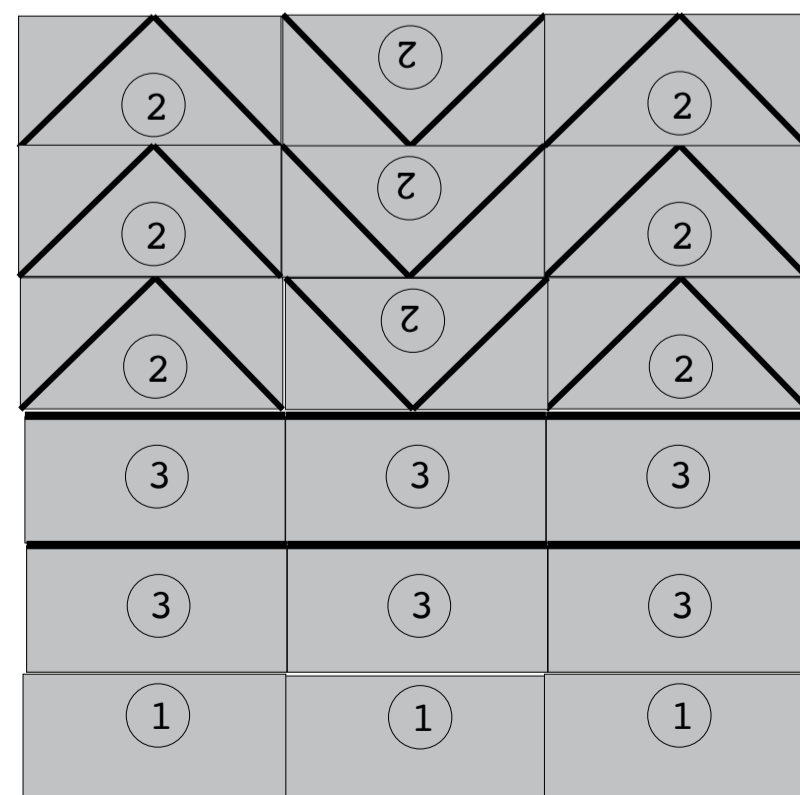

PATTERN "G"

© COPYRIGHT BY GIOVANNI BARBIERI AUGUST 2017

# DRAFT COLLECTION

CONCRETE-ENGINEERED MARBLE WITH MURANO GLASS INLAYS.  
INFINITIVE PATTERNS/INSTALLATION SOLUTIONS.



SURFACE DETAILS: THE GLASS WIDTH IS 6 MM - 2/8  
THE RELIEF OF THE SAME IS 2/8 - 5 MM APPROXIMATELY.

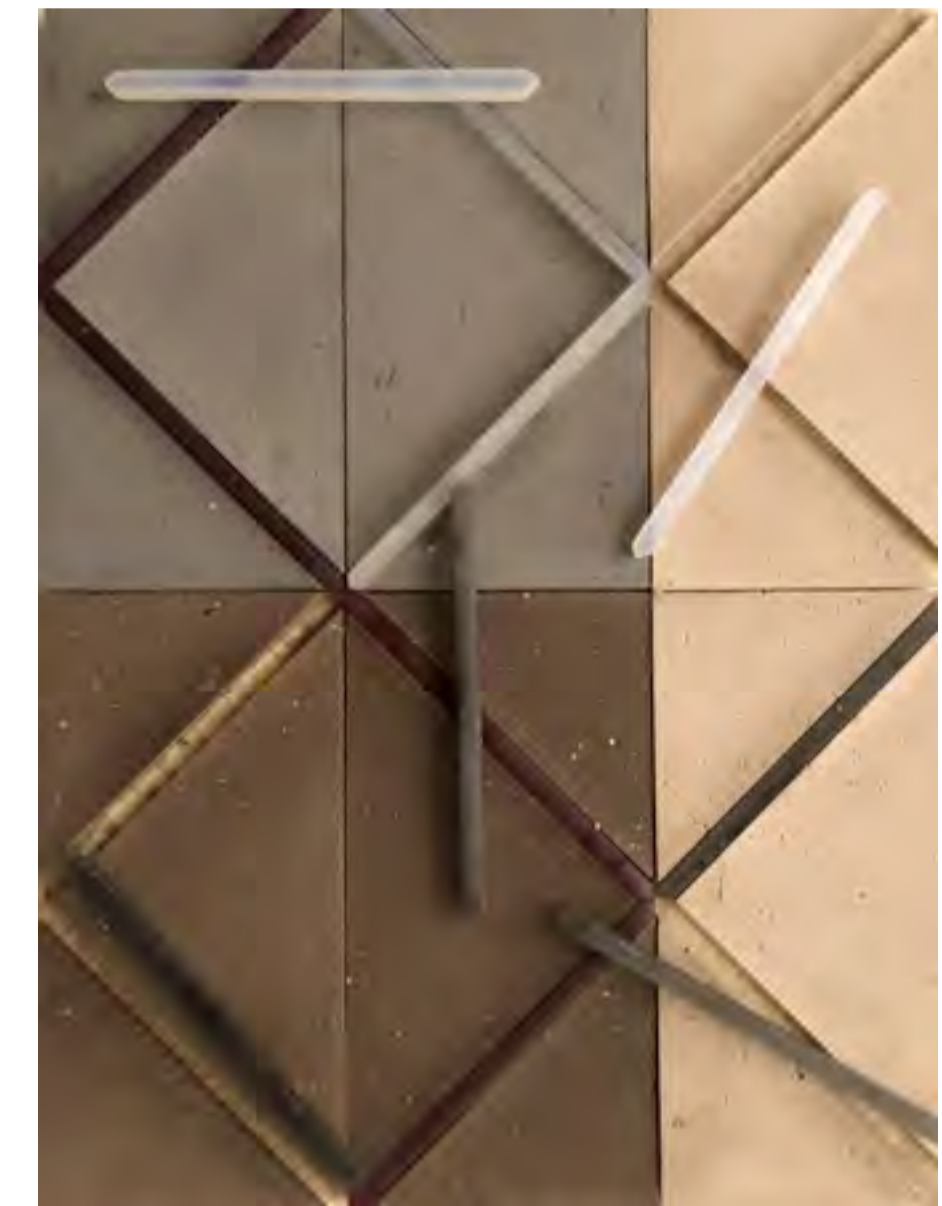

MURANO GLASS INLAYS ARE SUPPLIED SEPARATELY  
OFFERING MANY COMBINATION OPTIONS.

# BACCHETTE COLLECTION

CONCRETE-ENGINEERED MARBLE WITH MURANO GLASS INLAYS.  
RANDOM INSTALLATION SUGGESTED.  
SAME TECHNICS AND COMBINATION COLORS THAN ABOVE DRAFT COLLECTION.

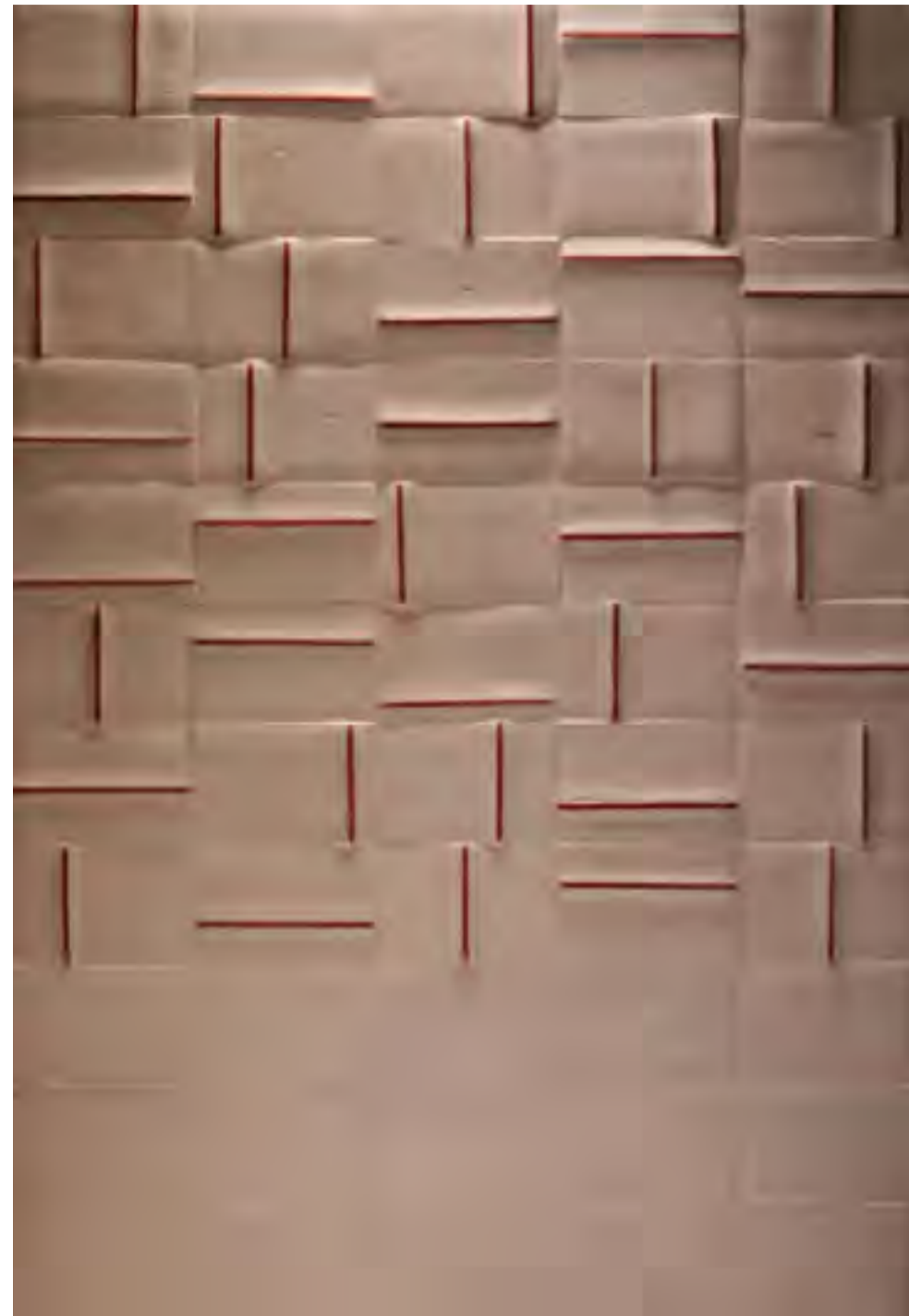

7 MODELS CM 8 x 12 x 1 / 3" 3/8 x 5" x 3/8

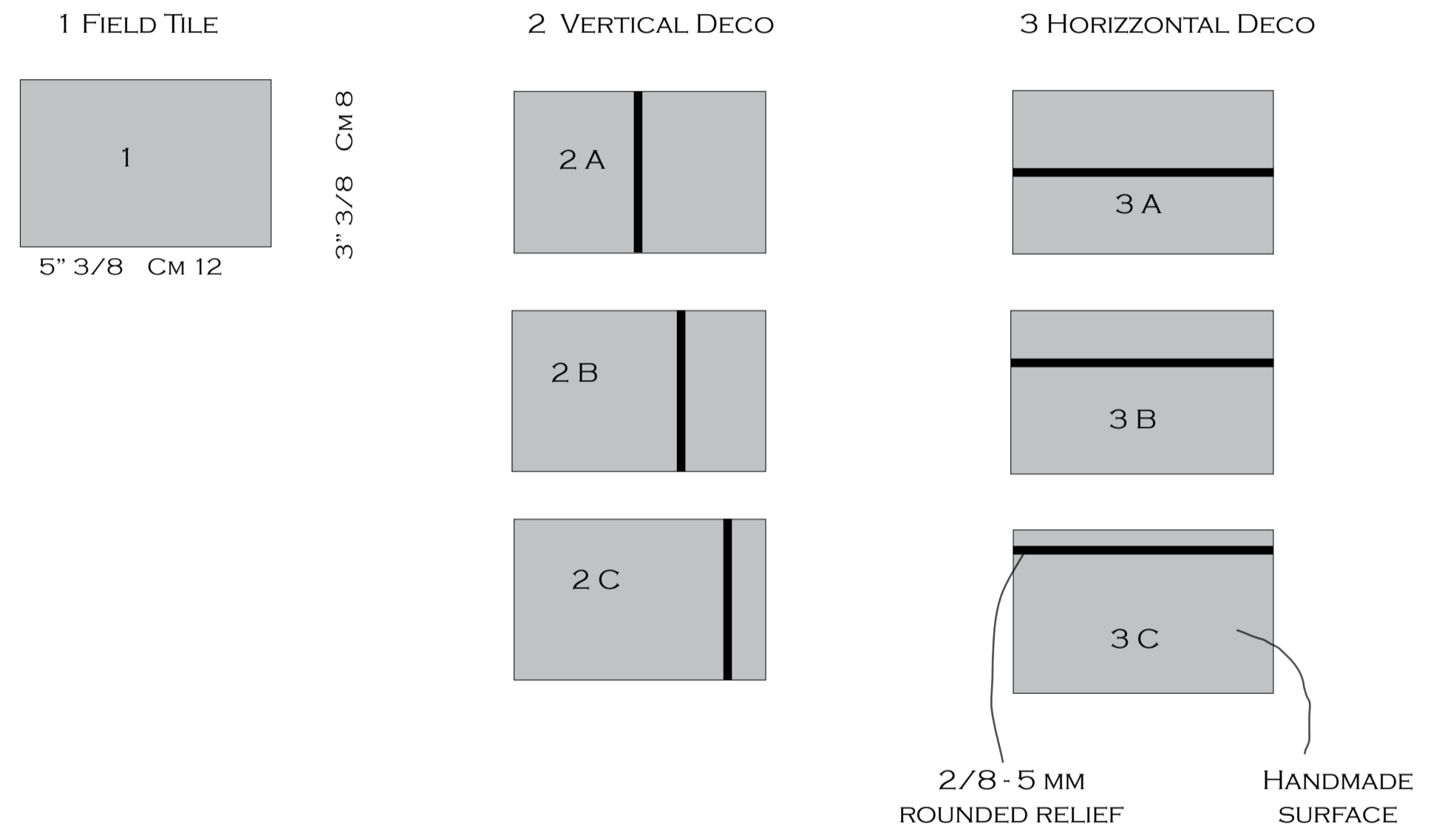

6 ENGINEERED MARBLE/CONCRETE COLOURS OPTION



INLAYS "LISTELLO" WOULD BE IN 6 DIFFERENT MURANO GLASS COLOURS OPTION.

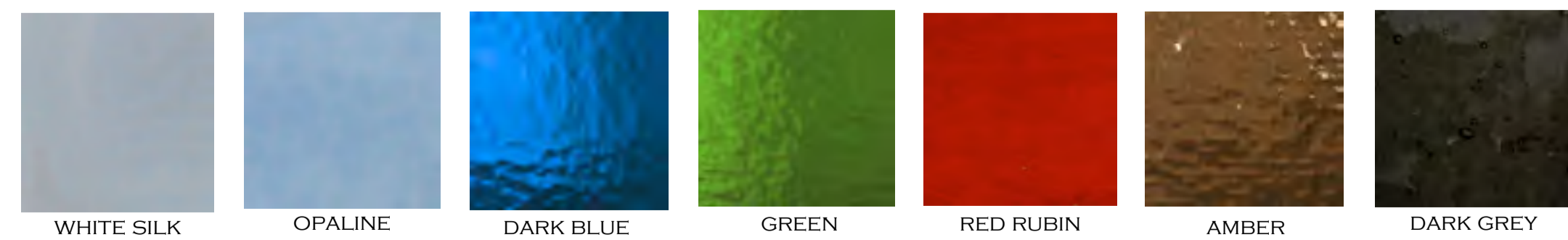

# BACCHETTE COLLECTION

CONCRETE-ENGINEERED MARBLE WITH MURANO GLASS INLAYS.  
RANDOM INSTALLATION SUGGESTED.

PATTERN 1

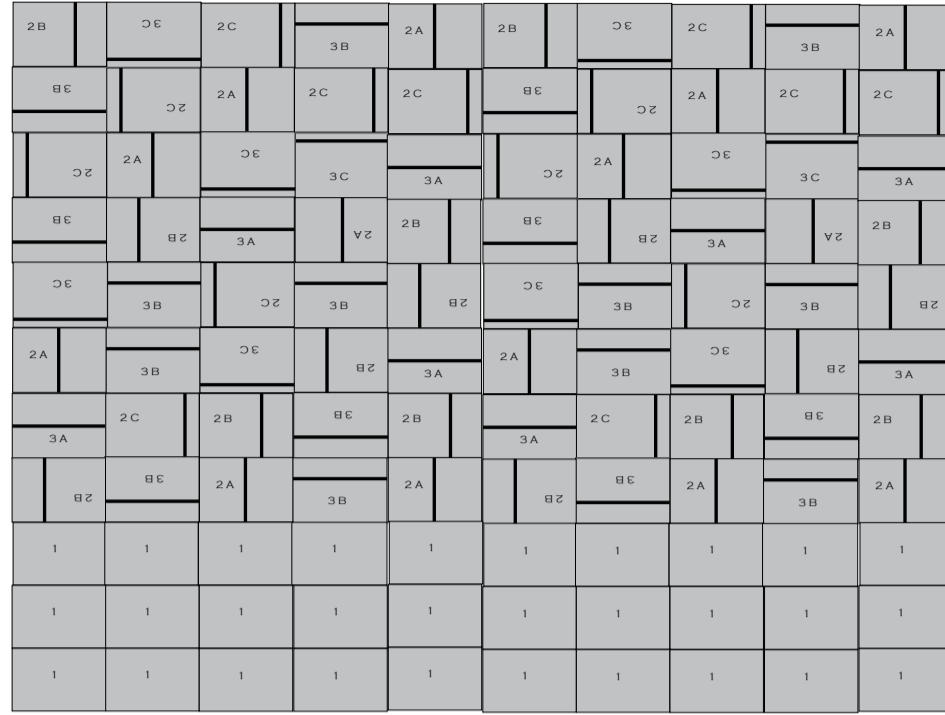

PATTERN 2

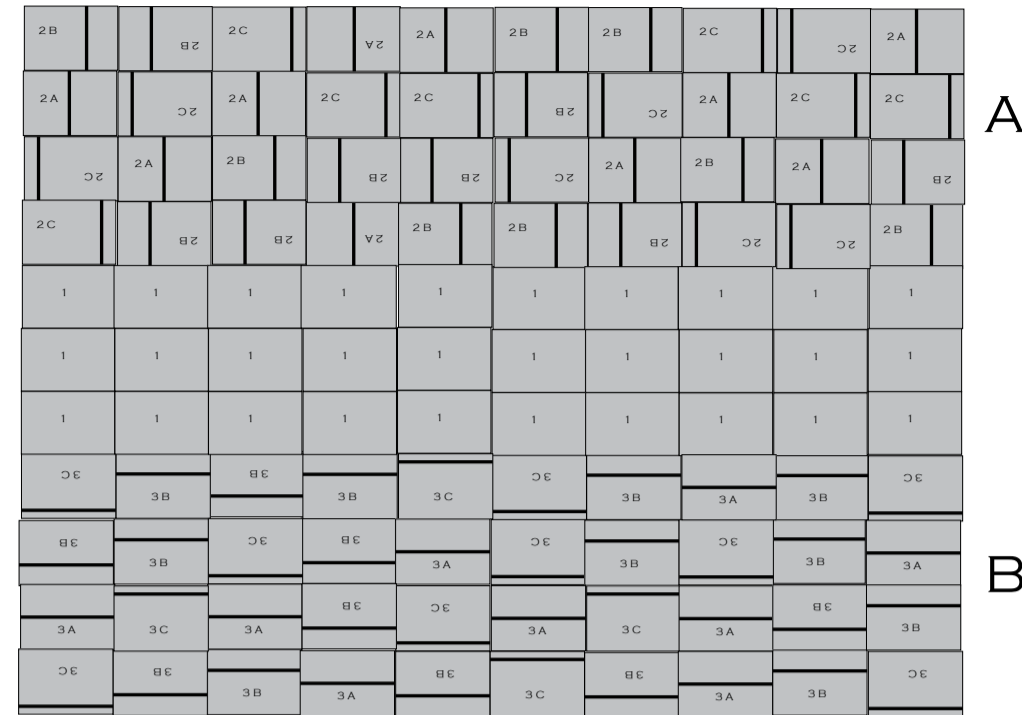

A

B

PATTERN 7 (FIT TO SIZE)

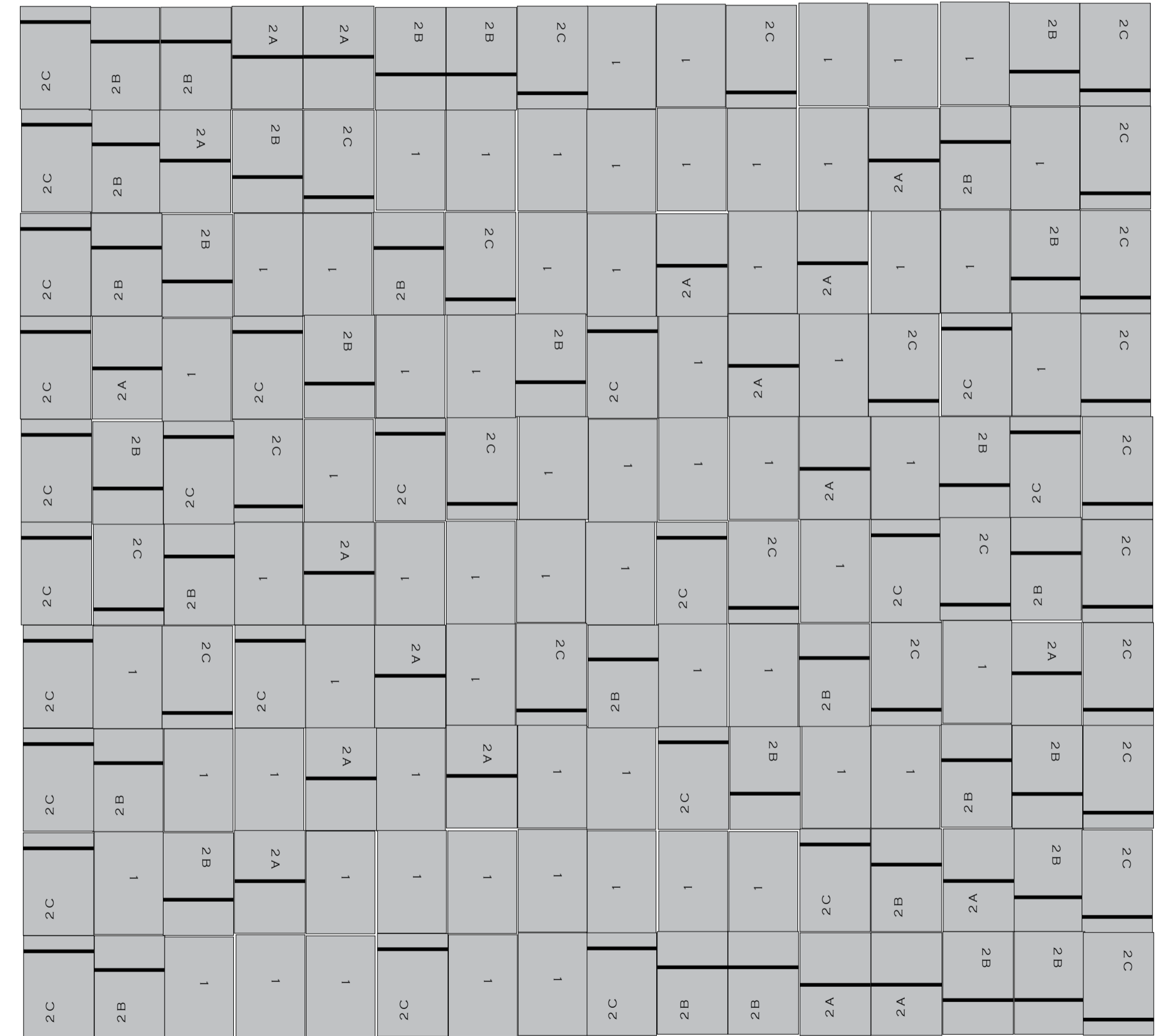

PATTERN 3 (FIT TO SIZE)

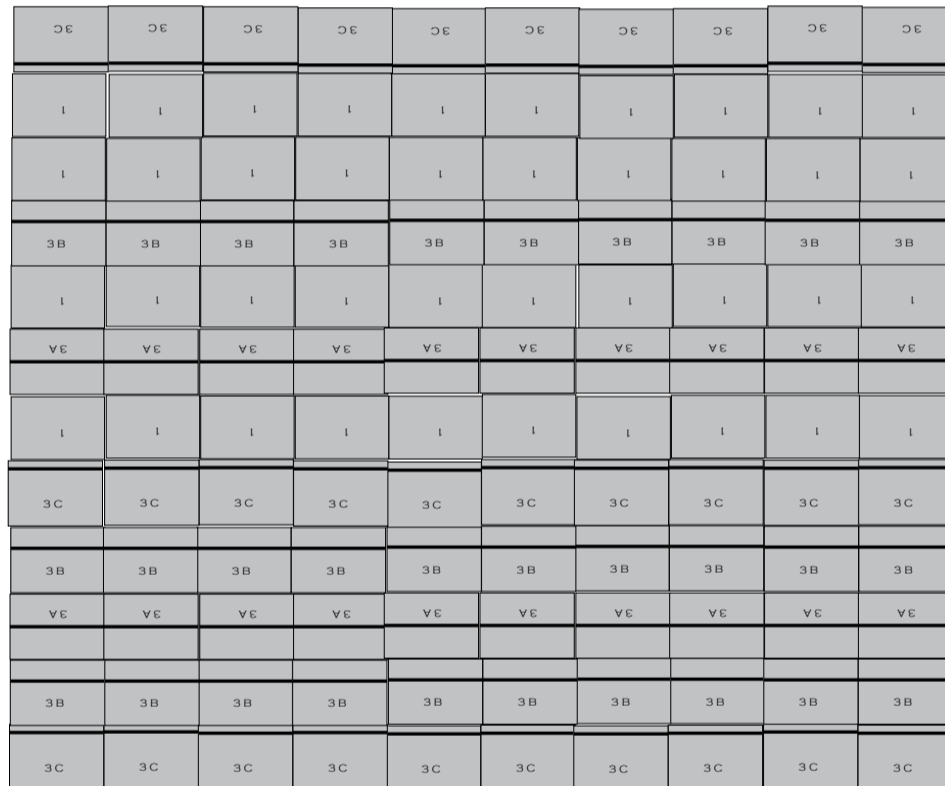

PATTERN 4

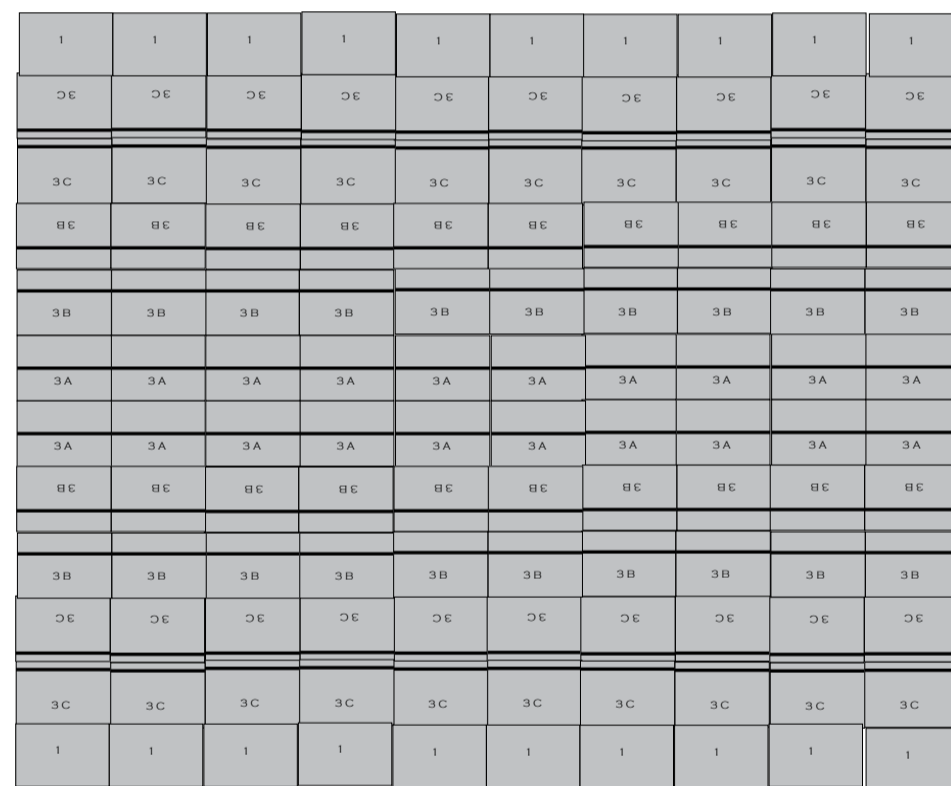

PATTERN 5 (FIT TO SIZE)

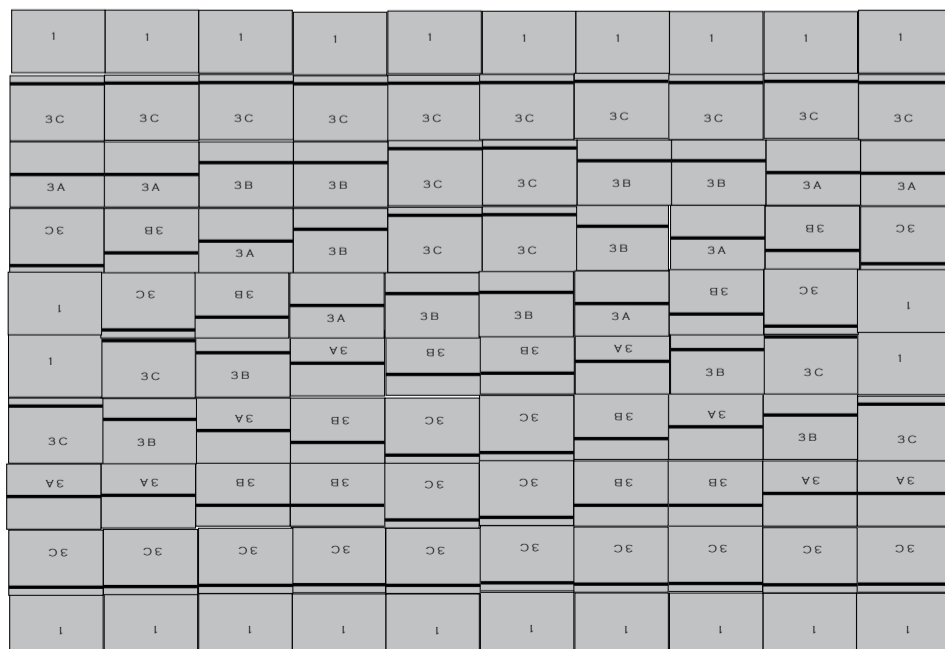

PATTERN 6

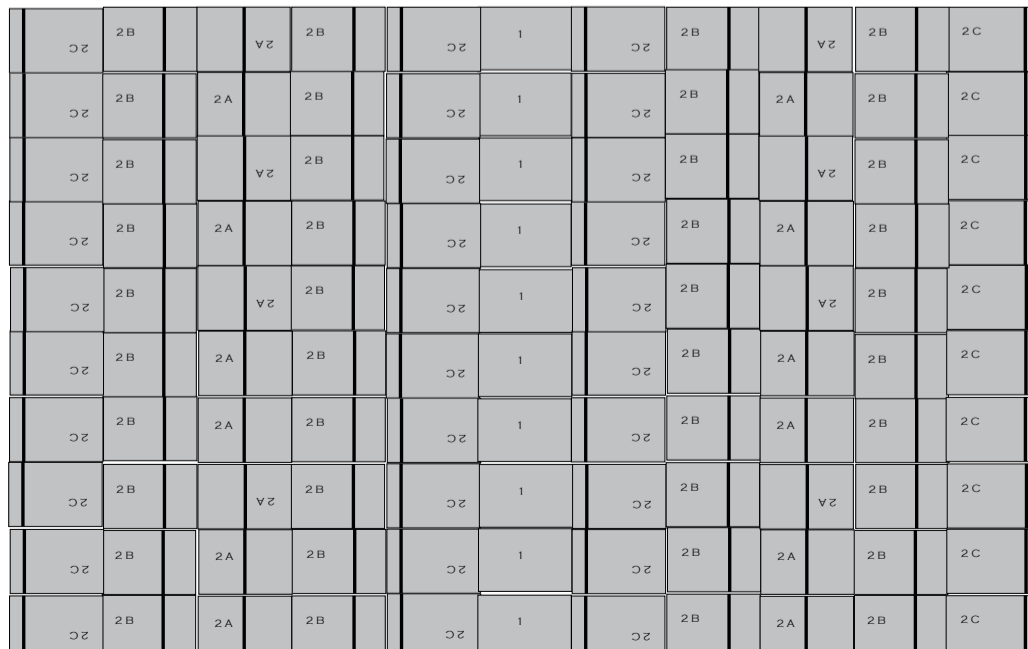



## “DEPTHILE”

“DEPTHILE COLLECTION” IS A SOPHISTICATED MINIMAL LOOK MIXING STRAIGHT AND CUSCION TILE EDGE WITH HONED POLISHED SURFACE SHADES: THE RESULT OBTAINED IS MINIMALIST AT FIRST SIGHT AND SOPHISTICATED IN THE SAME TIME ON THEIR DETAILS.

THE UNIQUE SHADING EDGE EFFECT ENHANCED BY SIMPLY NATURAL OR ARTIFICIAL LIGHTING OBTAIN DEPTH LOOK, AND IN THE SAME TIME, OFFERING A VERY EASY INSTALLATION AND CLEANING/MAINTENANCE .

“DEPTHILE” IS THE FIRST NATURAL STONE TILE HAVING SOFT THREE-DIMENSIONAL EFFECT MANTAIN IT’S FLAT SURFACE WITH REAL UNIQUE LOOK, SUITABLE FOR FLOOR AND WALL. THE CUSCION EDGE HELP TO OBTAIN NICE AND COMFORTABLE WALL COVERING TERMINAL FOR BATHROOM AND KITCHEN ALSO.

### “DEPTHILE COLLECTION”

IS AVAILABLE IN THE FOLLOWING SIZES:

2” x 12” x 3/8 / CM 5 x 30,5 x 1

3” x 18” x 3/8 / CM 7,5 x 45,7 x 1

ON MOST POPULAR NATURAL STONE  
AND  
ENGINEERED MARBLE OR CONCRETE UPON REQUEST.

### DESTINATION USE:

- BATHROOM AND KITCHEN BACKSPLASH
- BOUTIQUE WALLS AND FLOORS
- SPA WALL AND FLOOR ( CONCRETE OR ENGINEERED MARBLE VERSION)

WE WILL BE HAPPY TO HELP YOU DESIGN AND PRODUCE YOUR PROJECT IN THE BEST WAY YOU COULD DESIRE.

# DEPTHILE

2" x 12" x 3/8" / CM 5 x 30,5 x 1  
CARRARA MARBLE TILES.



# DEPTHILE

3" x 18" x 3/8" / CM 7,5 x 45,7 x 1  
CARRARA MARBLE TILES.



# DEPTHILE

3" x 18" x 3/8" / CM 7,5 x 45,7 x 1  
CARRARA MARBLE TILES.



## **ANTIQUED NATURAL STONE TILES**

A SELECTION OF RARE BEAUTY AESTHETIC RESULT  
THAT ARE A GENUINE REPRODUCTION OF  
ORIGINAL HISTORICAL VENETIAN FLOOR TILES.

SUITABLE FOR INTERIORS AND PATIO FLOOR ,  
AND ANY WALL USE.

WE WILL BE HAPPY TO HELP YOU DESIGN AND PRODUCE YOUR PROJECT  
IN THE BEST WAY YOU COULD DESIRE.



## BLUETTE TIMEWORN

AVAILABLE IN 2"- 4"- 6"  
CM 5-10- 15  
X FREE LENGTHS, ONLY.  
2/8 TO 1/2 THICKNESS  
THICKNESS 6 TO 12 MM



## HISTORICAL FLOOR

HOMOGENOUS GREY OR VARIEGATED BEIGE HARD COMPOSITION NATURAL LIMESTONE.  
HAND CUT EDGE AND ANTIQUED WAVY TIMEWORN SURFACE.  
STANDARD SIZES AVAILABLE 16" x 24" x 3/4 ( 40 x 60 x 2 CM ).  
OTHER SIZES AVAILABLE UPON REQUEST MAXIMUM 20" X FREE LENGTHS OR 24" X 36"



## TIMEWORN TILES

MACHINE CUT EDGE TILES IN NATURAL STONE AS HOMOGENOUS GREY LIMESTONE.

STANDARD SIZES AVAILABLE 16" x 24" x 3/4 ( 40 x 60 x 2 CM ).  
OTHER SIZES AVAILABLE UPON REQUEST MAXIMUM 20" x FREE LENGHTS OR 24" x 36"



## PEPPER GREY TIMEWORN TILES

MACHINE CUT EDGE TILES IN NATURAL STONE AS  
PEPPER GREY HARD COMPOSITION LIMESTONE.

STANDARD SIZES AVAILABLE 24" x 36" x 3/4 (61 x 91,5 x 2 CM).  
OTHER SIZES AVAILABLE UPON REQUEST MAXIMUM 24" x FREE LENGHTS



PEPPER GREY SIZE 24" x 36" x 3/4 CM 61 x 91,5 x 2



PEPPER GREY 24" x 36" x 3/4 CM 61 x 91,5 x 2 SIZE 24" x 36" x 3/4





## BIANCO ANTICO TIMEWORN TILES AND STAIRS

MACHINE CUT EDGE TILES IN NATURAL STONE AS BIANCO ANTICO ITALIAN MARBLE.

STAIR BULLNOSE EDGE FULLY HAND MADE SAME AS ITALIAN 18TH CENTURY.  
FOR INTERIORS RESIDENTIAL, ONLY.



**BIANCO ANTICO TIMEWORN TILES AND MOSAICS**  
MACHINE CUT EDGE TILES IN NATURAL STONE AS BIANCO ANTICO ITALIAN MARBLE.

2" x 2" OR 2" x 4" x 3/8 (CM 5 x 5 OR 5 x 10 x 1,0 THICKNESS)  
ON NET SIZE 1,00 SF



## BIANCO ANTICO TIMEWORN MOSAICS AND ETCHED TILES

THE "SPINA PESCE" MOSAIC IS MADE BY 1" - 1" 1/2 AND 2" X 6" LENGTHS  
ON NET SIZE 0,33 SF, TOTAL THICKNESS CM 1  
ETCHET TILES ARE CUSTOM MADE AS PER NATURAL STONE COLOURS, DRAWING AND SIZE.  
WE WILL BE HAPPY TO HELP YOU DESIGN AND PRODUCE YOUR PROJECT  
IN THE BEST WAY YOU COULD DESIRE,  
EVEN FOR A UNIQUE EXCLUSIVE DESIGN AND CUSTOM MADE SINGLE PRODUCTION, ONLY.

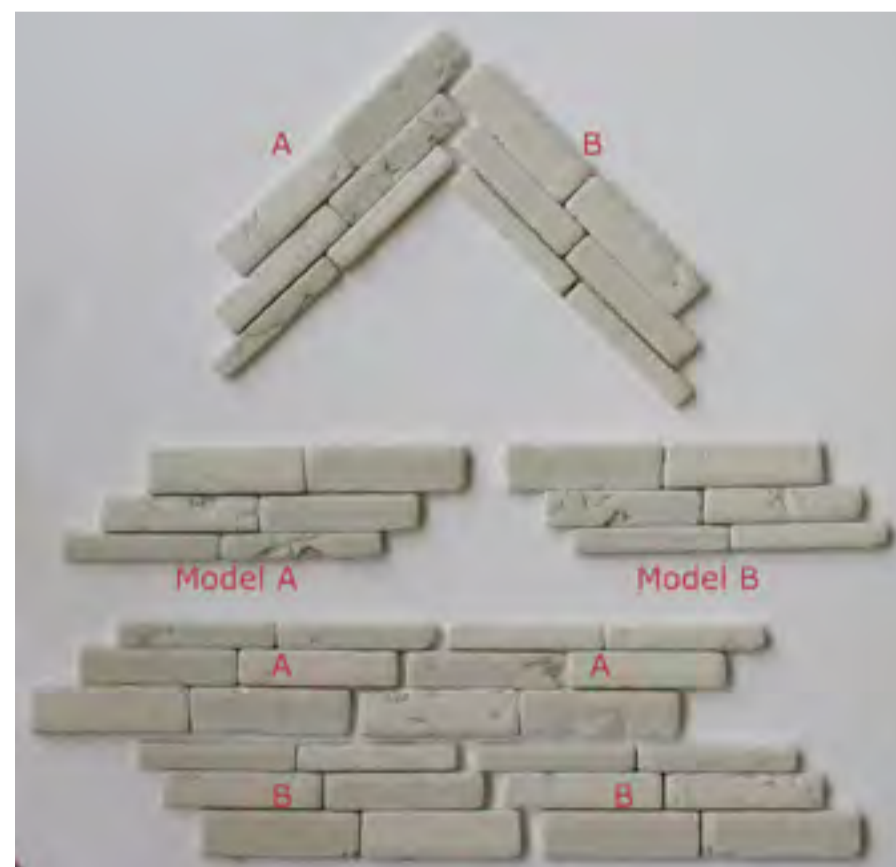
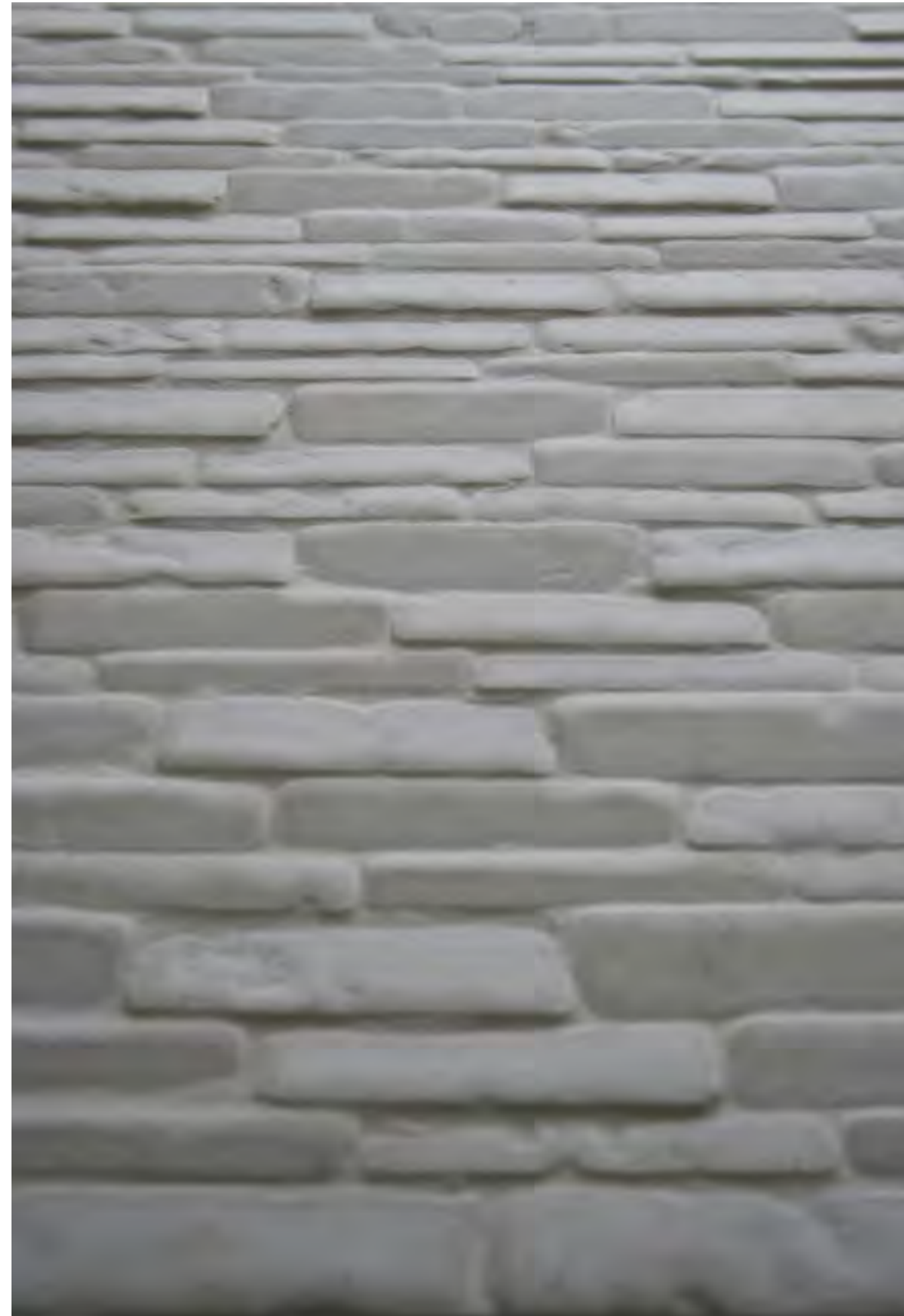

TIMEWORN MOSAICS  
CUSTOM MADE

ON ANY NATURAL STONE COLOURS, DRAWING AND SIZE.

BLACK LIMESTONE, 2" x 2" x 3/8 (CM 5x5x1) ON NET SIZE 12"x12" x 3/8 (CM 30,5 x 30,5 x 1)



NOCE TRAVERTINE 2" x 2" x 3/8 ON 1,0 SF NET



DNA DESIGN ON BIANCO CARRARA 6" X 24" X 3/8 ( 15 X 61 X 1 CM ) TILES INSTALLED ON NEIMANN MARCUS BOUTIQUE IN TROY, MICHIGAN USA,

## CARRARA TIMEWORN MOSAICS AND ETCHED TILES

MACHINE CUT EDGE TILES IN NATURAL STONE AS BIANCO ANTICO ITALIAN MARBLE.

THE "SPINA PESCE" MOSAIC IS MADE BY 1" - 1" 1/2 AND 2" X 6" LENGTHS  
ON NET SIZE 0,33 SF, TOTAL THICKNESS CM 1

ETCHET TILES ARE CUSTOM MADE  
ON ANY NATURAL STONE COLOURS, DRAWING AND SIZE.



CARRARA 2" X 2" X 3/8 ON 1,0 SF NET



Courtesy of Amiel Garcia Showroom Manager / Country Floors LA



BATHROOM WALL SLABS CM 56 x 101 x2 ( 22"x 40" )

SURFACE DETAIL



## ETCHED "WAVE DRAWING" TEXTURES TILES

NATURAL STONE ETCHED AND WAVY HIGH HONED OR POLISHED SURFACE TILES  
TOTALLY CUSTOME MADE AS PER DRAWING, SIZES, AND NATURAL STONE COLOURS.

RENAISSANCE DESIGN ON 12" x 12" x 3/8 BIANCO ANTICO MARBLE TILES.



## CHOCOLATE STONE BORDERS

HAND-FUSED LAYERS OF MULTI COLORED MARBLE, ONIX, LIMESTONE,  
SIZE 2"x2" /CM 5x5 BASE. AVAILABLE IN GREEN, BROWN, WHITE GREY AND BEIGE NUANCES.  
PACKAGED ON 2" X 12" / CM 5 X 30 ( 6 PCS ) BORDER.



## ITALIAN PORCELAIN TILES

ITALIAN HIGH QUALITY FULL BODY COLORED PORCELAIN TILES.

MEMENTO COLLECTION IS INTERIOR DESIGN MAGAZINE  
BEST OF YEAR AWARD WINNER ON SOLID SURFACE CATEGORY.



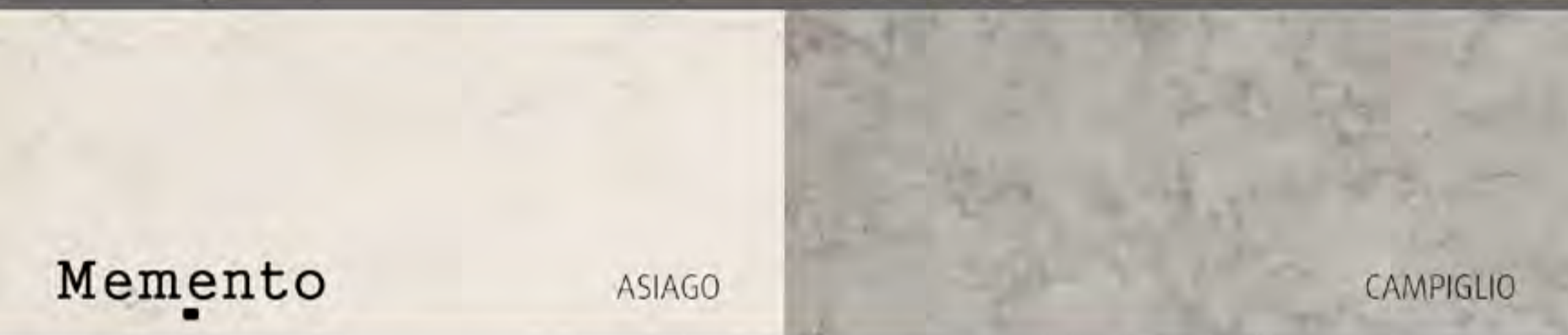
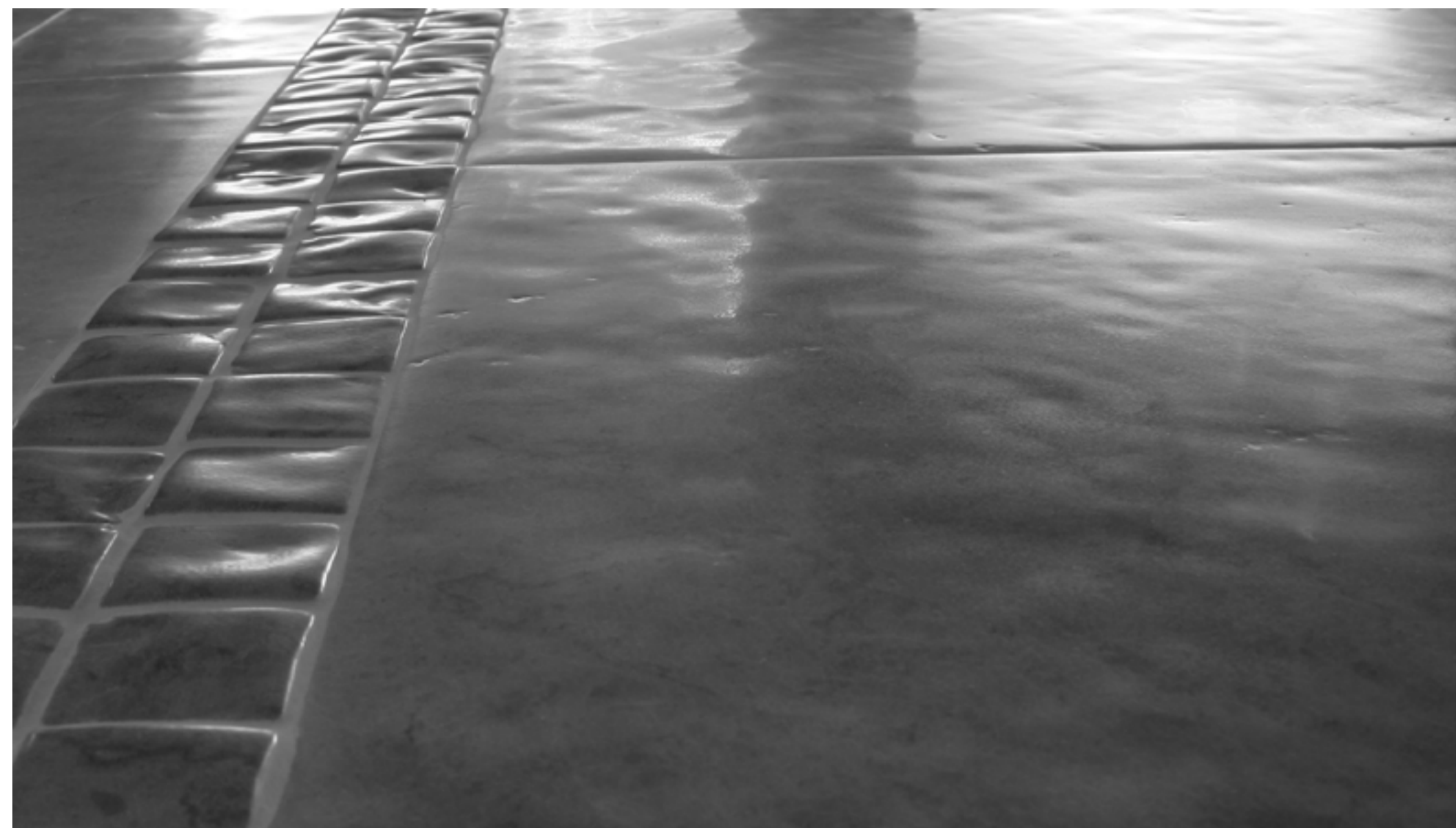

Memento

ASIAGO

CAMPIGLIO

FORMATI - format



DIGITAL TECHNOLOGY  
GRES PORCELLANATO  
IMPARTO CALORATO

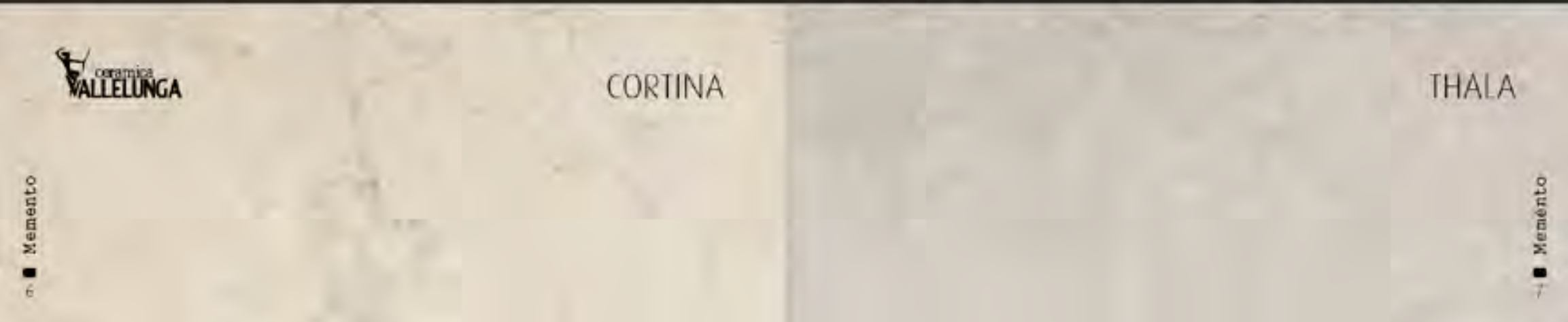

ceramica VALLELUNGA

CORTINA

THALA

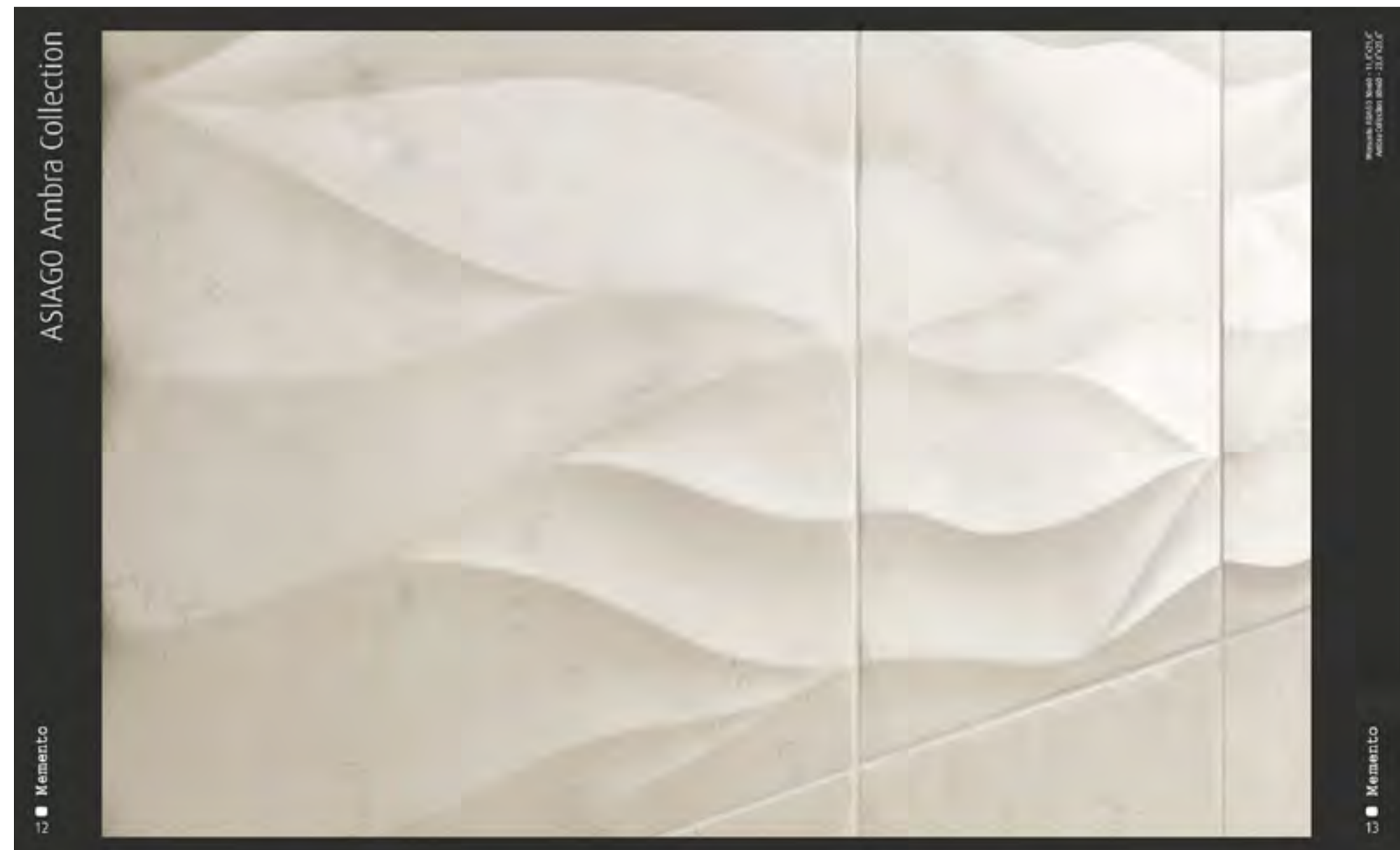

ASIAGO Ambra Collection

Mosaike 30x30 3x3 - 11,8" x 11,8"  
Mosaike 30x30 3x3 - 11,8" x 11,8"

Memento



GRES PORCELLANATO				
CARATTERISTICHE TECNICHE				
TECHNICAL CHARACTERISTICS / CARACTÉRISTIQUES TECHNIQUES / TECHNISCHE EIGENSCHAFTEN				
CONFORME	CONFORME	CONFORME	CONFORME	CONFORME
	<b>ASSORBIMENTO D'ACQUA</b> WATER ABSORPTION ANALPHON D'EAU WASSERANSAUGFÄHIGKEIT	EN ISO 10545-2	0,34 (0,34)	0,05
	<b>RESISTENZA ALLA PITTURA</b> RESISTANCE TO PAINTING RÉSISTANCE À LA PEINTURE BESITZUNGSFÄHIGKEIT	EN ISO 10545-4	150 Punkte 112 Kg P110 H	CONFORME
	<b>DUREZZA MOHE</b> MOH'S HARDNESS DURETÉ MOHÉ HÄRTE	EN ISO 10	NON RICHIESTO Not required	NON RICHIESTO
	<b>RESISTENZA ALL'ABRASSIONE</b> ABRASION RESISTANCE RÉSISTANCE À L'ABRASION ABRASIONSWIDERSTÄNDIGKEIT	EN ISO 10545-7	NON RICHIESTO Not required	AMMIO DI PUNTA PEAK VALUE ED V
	<b>RESISTENZA AGLI UALZI TERMICI</b> THERMAL SHOCK RESISTANCE RÉSISTANCE AUX CHOC THERMIQUES TEMPERATURSCHOCKWIDERSTÄNDIGKEIT	ASTM C672	RICHIESTO required	RESISTENTE
	<b>RESISTENZA ALL'ATTACCO CHIMICO</b> CHEMICAL RESISTANCE RÉSISTANCE CHIMIQUE CHEMISCHWIDERSTÄNDIGKEIT	EN ISO 10545-13	NON RICHIESTO Not required	RESISTENTE
	<b>RESISTENZA AL FRECCO</b> FROST RESISTANCE RÉSISTANCE AU FROST FROSTWIDERSTÄNDIGKEIT	EN ISO 10545-12	NON RICHIESTO Not required	RESISTENTE
	<b>RESISTENZA ALLE MACCHIE</b> STAIN RESISTANCE RÉSISTANCE AUX TACHES FLECKENWIDERSTÄNDIGKEIT	EN ISO 10545-14	NON RICHIESTO Not required	RESISTENTE
	<b>Coefficiente di attrito dinamico</b> DYNAMIC FRICTION COEFFICIENT DYNAMISCHER REIBKOEFFIZIENT	ISO 2000 EN 12518	0,42	0,49
	<b>CARATTERISTICHE DIMENSIONALI</b> DIMENSIONAL CHARACTERISTICS DIMENSIONEN	ASTM C493 Present Vorhanden	1,2 mm 0,1 mm 1,2 mm 0,1 mm	CONFORME
		ASTM C498 Dimensione Dimension	1,2 mm 0,1 mm 1,2 mm 0,1 mm	CONFORME
		ASTM C499 Spessore Thickness	1,2 mm 0,1 mm 1,2 mm 0,1 mm	CONFORME
		ASTM C502 Prestazione Wedding	1,2 mm 0,1 mm 1,2 mm 0,1 mm	CONFORME

AMOUNT OF COLOUR VARIATION

**V3**  
HIGH COLOUR VARIATION

Vallelunga's MEMENTO tiles contribute to gaining lead credits in the MR 4.1, MR 4.2 and EQ 4.2 categories.

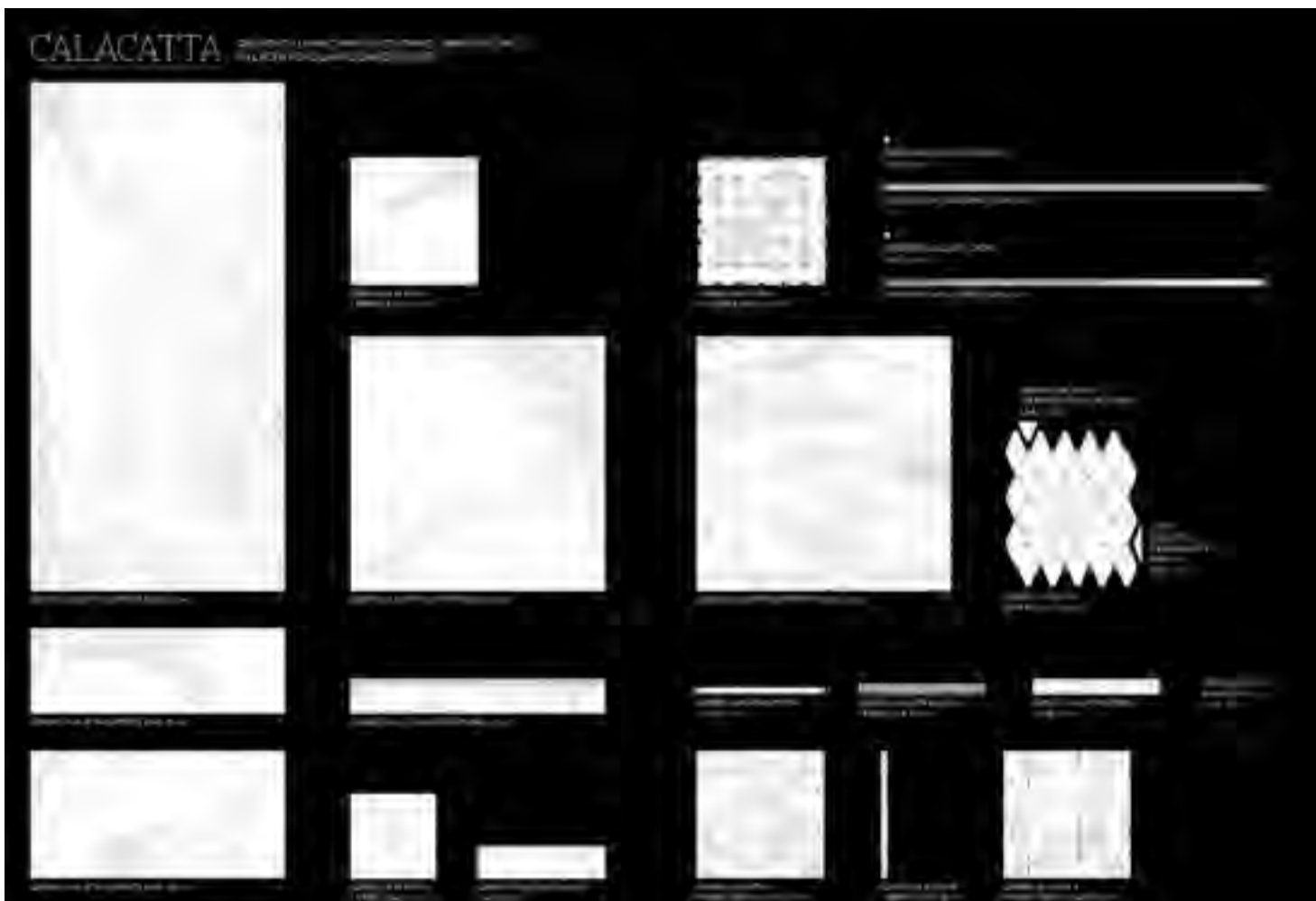

# VINTAGE CALACATTA

ITALIAN HIGHEST QUALITY FULL BODY COLORED PORCELAIN TILES.



CARATTERISTICHE TECNICHE				GRES PORCELLANATO
Technical Characteristics - Caracteristiques Techniques - Technische Eigenschaften				INFIATTO COLGALATO
CONFORME - ACCORDING TO - CONFORME - GEFÜB: ANSİ 137.1 Impervious porcelain tiles				
Vallelunga & Co	CARATTERISTICHE TECNICHE TECHNICAL CHARACTERISTICS CARACTERISTIQUES TECHNIQUES TECHNISCHE EIGENSCHAFTEN	METODO DI PROVA ASTM TEST METHOD ASTM METHODE D'ESSAI ASTM PRÜFVERFAHREN ASTM	REQUISITI PRESCRITTI Required Value Valeur Prescrite Vorgeschriebener Wert ANSI 137.1	VALORI Values/Values VALLERUNGA SMALTIATO GLAZED GL
	<b>ASSORBIMENTO D'ACQUA</b> WATER ABSORPTION ABSORPTION D'EAU WASSERABSORPTION	EN-ISO 10545-3	≤ 0.5% (fully vitrified)	≤ 0,05
	<b>RESISTENZA ALLA ROTTURA</b> BREAKING MODULUS RÉSISTANCE À LA FLEXION BIEGESTÄRKE	EN-ISO 10545-4	≥ 250 Pounds ≥ 113 Kg ≥ 1110 N	CONFORME Compliant
	<b>DUREZZA MOHS</b> MOHS HARDNESS DURETÉ MOHS HÄRTE MOHS	EN-ISO 101		MOHS 5
	<b>RESISTENZA ALL'ABRAZIONE</b> ABRASION RESISTANCE RÉSISTANCE À L'ABRASION ABRASIONSWIDERSTÄNDIGKEIT	EN-ISO 10545-7	NON RICHIESTO Not required	METODO DI PROVA ISO 10545-7 PE IV
	<b>RESISTENZA AGLI SBALZI TERMICI</b> THERMAL SHOCK RESISTANCE RÉSISTANCE AUX CHOC THERMIQUES TEMPERATURWECHSELBESTÄNDIGKEIT	ASTM C484	RICHIESTO required	RESISTENTE Resistant
	<b>RESISTENZA ALL'ATTACCO CHIMICO</b> CHEMICAL RESISTANCE RÉSISTANCE CHIMIQUE CHEMISCHE BESTÄNDIGKEIT	EN-ISO 10545-13	NON RICHIESTO Not required	RESISTENTE Resistant
	<b>RESISTENZA AL GELO</b> FROST RESISTANCE RÉSISTANCE AU GEL FROSTBESTÄNDIGKEIT	EN-ISO 10545-12	NON RICHIESTO Not required	RESISTENTE Resistant
	<b>RESISTENZA ALLE MACCHIE</b> STAIN RESISTANCE RÉSISTANCE AUX TACHES FLÜCKENBESTÄNDIGKEIT	EN-ISO 10545-14	NON RICHIESTO Not required	RESISTENTE Resistant
	<b>COEFFICIENTE DI ATTRITO DINAMICO</b> DYNAMIC FRICTION FROTTEMENT DYNAMIQUE DYNAMISCHE REIBUNG	BOI 3000 ANSI A 137.1	WET ≥ 0.42	CONFORME Compliant
	<b>CARATTERISTICHE DIMENSIONALI</b> DIMENSIONS CARACTÉRISTIQUES DIMENSIONNELLES SEITENMAßE	ASTM C485 Planarity Warpage	≤ 1,0% Su lati/On sides ≤ 0,75% sulle diagonali/On diagonals	CONFORME Compliant
		ASTM C499 Dimensions Dimensions	≤ 3,0% Sulle dimensioni nominali Of nominal dimensions ≤ 1,5% Differenza nel lotto tra valori min. e max./Difference in batch between min. and major values	CONFORME Compliant
		ASTM C499 Spessore Thickness	≤ 0,040 inch Differenza nel lotto tra spessore min. e max./ Difference in batch between min. and major thickness	CONFORME Compliant
		ASTM C502 Parallelismo dei lati Wedging	≤ 1,0 %	CONFORME Compliant



FOUSSANA  
MUD



FOUSSANA  
SAND

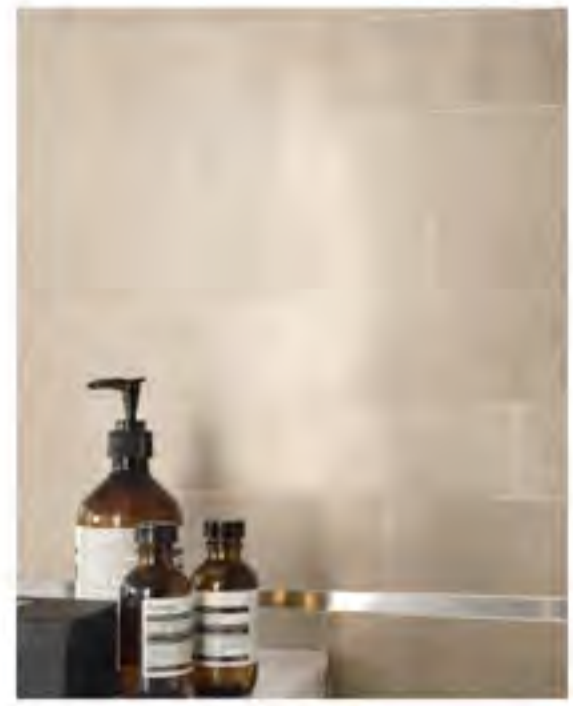

Dimensioni  
450x450  
450x900  
900x900  
Pacchetto 10/20/30  
Resistenza Ceramica 3.000 N/cm²

VINTAGE FOSSANA.  
ITALIAN HIGHEST QUALITY FULL BODY COLORED PORCELAIN TILES.

**CARATTERISTICHE TECNICHE**  
Technical Characteristics / Caratteristiche Tecniche / Technische Eigenschaften  
COPPOLETTI - Via Cavallotti 11 - 41018 F. S. MARINO (MO) - Tel. 0421/871111 - www.coppoletti.it

**TRE PORCELLANATO**  
3600x1200

VALORI	CARATTERISTICHE TECNICHE TECHNICAL CHARACTERISTICS CARACTÉRISTIQUES TECHNIQUES TECHNISCHE DATEN	METODO DI PROVA ASTM	SPESIMENI PRESENTATI	VALORI VALLELUNGA
2	<b>ASSORBIMENTO D'ACQUA</b> WATER ABSORPTION ABSORPTION D'EAU WASSERANNAHME	EN 12518-1	0,10% (p < 0,0001)	2
4	<b>RESISTENZA ALLA ROTTURA</b> BASKING MODULE RESISTANCE CALCAE BRUCHWIDERSTAND	EN 12518-4	4500 N/mm² (110% +110%)	4
5	<b>DUREZZA MOHS</b> MOHS HARDNESS DURETE MOHS HÄRTE MOHS	EN 12518-1	6	5
7	<b>RESISTENZA ALL'ABRAZIONE</b> ABRASION RESISTANCE RESISTANCE A L'ABRASION ABRASIONSWIDERSTAND	EN 12518-1	EN 12518-1 10000 cycles	7
8	<b>RESISTENZA AGLI SBALZI TERMICI</b> THERMAL SHOCK RESISTANCE RESISTANCE AUX CHANGEMENTS TEMPERATURELS WÄRMESCHOCKWIDERSTAND	EN 12518-1	100°C	8
9	<b>RESISTENZA ALL'ATTACCO CHIMICO</b> CHEMICAL RESISTANCE RESISTANCE A L'ATTACQUE CHIMIQUE CHEMISCHER WIDERSTAND	EN 12518-1	EN 12518-1 1000 cycles	9
10	<b>RESISTENZA AL GELO</b> FROST RESISTANCE RESISTANCE AU GEL EINFROSTWIDERSTAND	EN 12518-1	EN 12518-1 1000 cycles	10
11	<b>RESISTENZA ALLE MACCHIE</b> STAIN RESISTANCE RESISTANCE AUX TACHES FLECKENWIDERSTAND	EN 12518-1	EN 12518-1 1000 cycles	11
12	<b>COEFFICIENTE DI ATRITO DINAMICO</b> DYNAMIC COEFFICIENT OF FRICTION COEFFICIENTE DINAMIC DYNAMISCHER KRIEBKOEFFIZIENT	EN 12518-1	EN 12518-1 0,10	12
13		EN 12518-1	EN 12518-1 0,10	13
14		EN 12518-1	EN 12518-1 0,10	14
15	<b>CARATTERISTICHE DIMENSIONALI</b> DIMENSIONAL CHARACTERISTICS DIMENSIONALE EIGENSCHAFTEN	EN 12518-1	EN 12518-1 0,10	15
16		EN 12518-1	EN 12518-1 0,10	16
17		EN 12518-1	EN 12518-1 0,10	17

AMOUNT OF COLOUR VARIATION **V3** HIGH COLOR VARIATION

FOUSSANA  
GRAY

Vallelunga & Co.



VINTAGE FOSSANA.  
ITALIAN HIGHEST QUALITY FULL BODY COLORED PORCELAIN TILES.

FOUSSANA  
MUD

Vallelunga & Co.



## **HANDMADE ANTIQUED TERRACOTTA**

WE ARE PROUD TO INTRODUCE LATEST ADVANGARDE RESULT OF  
ANTIQUED HANDMADE TERRACOTTA .

THE RESULT IS A UNCOMPARABLE COMBINATION OF  
TIMEWORN, IRREGULAR WAVY SURFACE FINISHING TEXTURE ,  
AND SPECTACULAR BLACK COLOUR,  
IT HAVE HONED-POLISHED SURFACE EACH SINGLE TILE IN DIFFERENT PERCENTAGE  
THAT FOLLOW THE DENSITY OF THE SURFACE AND BODY STRUCTURE;  
THIS DETERMINATE FINALLY THE FIRST BLACK COLOUR TILES COLLECTION  
OFFERING EASY CLEANING AND MAINTENANCE SURFACE.

DUE TO ITS TIMEWORN SURFACE AND OLD LOOK,  
SIZES DEVELOPED ARE SUITABLE FINALLY ON

MINIMALIST INTERIOR DESIGN STYLE CONCEPTS  
WHICH GIOVANNI BARBIERI STRONGLY BELIEVE THE MARKET NEED.

AVAILABE VERY SOON IN DIFFERENT NUANCES AND SIZES ALSO.

WE SUPPLY PRESEALED FOR HELP EASY INSTALLATION AND GROUTING.  
FINAL SEALER APPLICATION IS SUGGESTED AT INSTALLATION TOTALLY COMPLETED.

HANDMADE ANTIQUED TERRACOTTA  
BLACK COLOR, SIZE CM 17 x 47 x 2,5 - 7" x 18" 1/2 x THICKNESS 1"





BLACK LIMESTONE, 4" x 40" x 1" 1/4 CM 10 x 100 x 3



## EXTERIOR FLOOR

DIRECTLY THROUGH OUR TRUST SUPPLIERS IN INDIA,  
WE HELP TO OBTAIN NICE AESTHETICAL RESULT AT VERY REASONABLE COST.

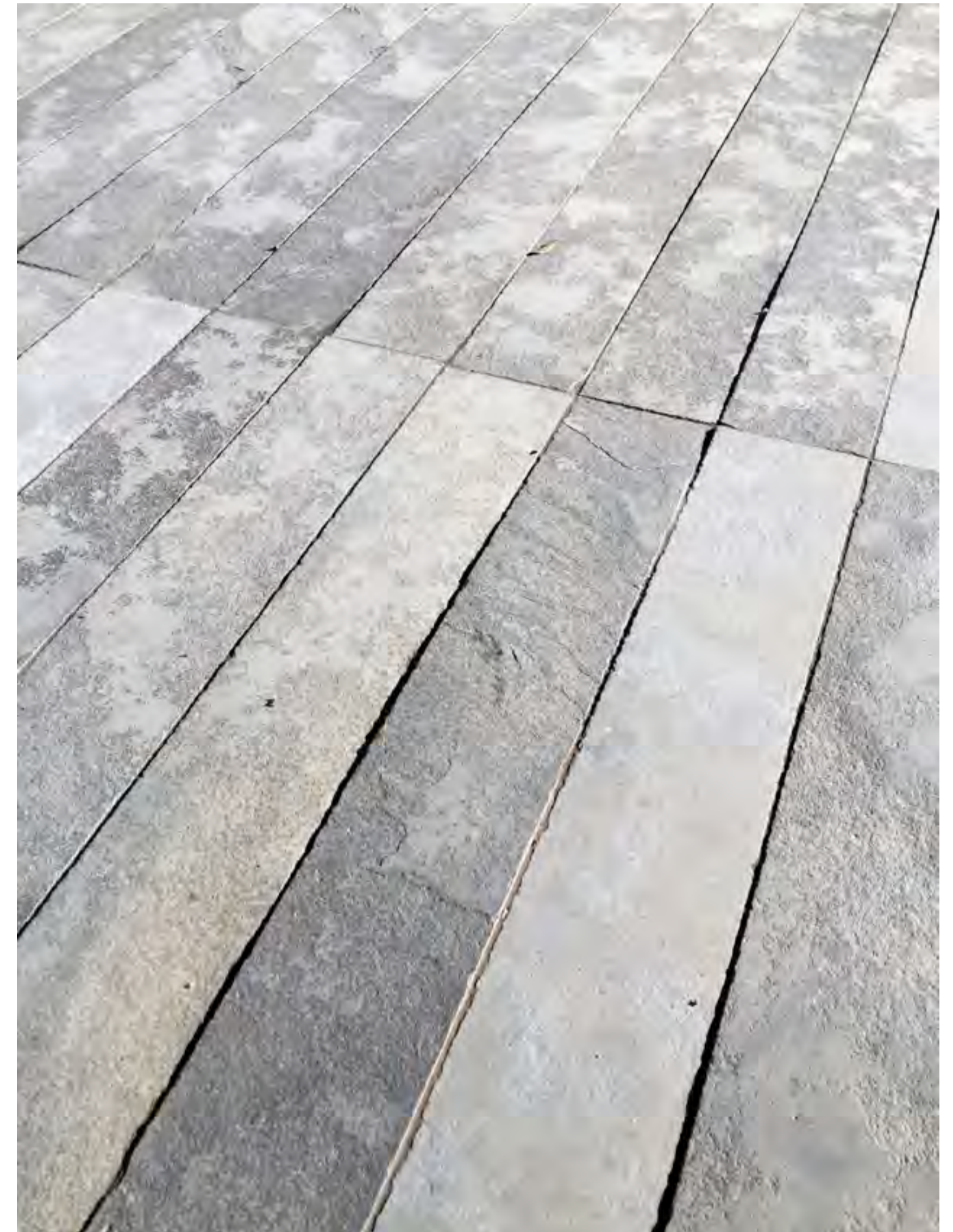

BLACK LIMESTONE, 4" x 40" x 1" 1/4 CM 10 x 100 x 3  
NATURAL SPLIT SURFACE PARTIALLY HONED



## THE MURANO COLLECTION

# THE MURANO COLLECTION

BREATHE NEW LIFE INTO HISTORICAL ITALIAN MATERIALS SUCH AS :

UMBRIA / TUSCANY/ VENETIAN HAND-MADE TERRACOTTA  
AND  
VENICE/MURANO GLASS

THAT COMBINED WITH NATURAL STONES  
ORIGINATE A STUNNING NEW GENERATION OF DECORATIVE SLABS  
FEATURING A UNIQUE DUAL AESTHETIC RESULT :

A THREE-DIMENSIONAL SURFACE WITH GRAZING LIGHT  
OF MURANO GLASS IN RELIEF, THAT REMAINS  
MONOCHROM IF NOT BACKSIDE - ILLUMINATED,  
CREATING A HARMONIOUS PLAY OF CURVED SURFACES.

THE BACKLIGHTING OF THE SLABS RAISES THE VALUE OF COLOUR EFFECTS  
AND TEXTURES ATTAINABLE WITH THE HAND-MADE MURANO GLASS, ONLY.

THE MURANO COLLECTION OFFERS AN UTTERLY  
UNIQUE AESTHETIC, AVAILABLE IN INFINITIVE  
VARIETY OF COLOURS, PATTERNS AND DIMENSIONS.

**THE MURANO GLASS** IS GLASS MADE ON THE VENETIAN ISLAND OF MURANO WHICH HAS SPECIALIZED IN FANCY GLASSWARE FOR CENTURIES. MURANO'S GLASSMAKERS LED EUROPE FOR CENTURIES, DEVELOPING OR REFINING MANY TECHNOLOGIES. VENETIAN GLASS IS WORLD-RENOWNED FOR BEING COLOURFUL, ELABORATE AND SKILFULLY MADE. TODAY, THE ARTISANS LIVING AND WORKING IN VENETIAN AREA ARE STILL EMPLOYING OLD TECHNIQUES AND ARE ABLE TO PRODUCE SLABS OF 30CM X 60CM AND OF 1 CM THICKNESS THAT THE BARBIERI ARTISANS CRAFT AND CUT OUT BY WATERJET FOR THEIR OWN PERFORMANCES. THE PRECIOUS ABILITY OF THE BARBIERI CRAFTSMANSHIP GIVES THE POSSIBILITY OF HAVING ANY GLASS COLOUR ON DEMAND. AT THE SAME TIME ONE MUST NOTE THAT FOR EACH FUSION THE COLOUR SHADES MIGHT VARY AND ARE NEVER THE SAME UNAVOIDABLE FACTORS WHICH REPRESENT THE ORIGINALITY AND ARTISTIC CRAFTSMANSHIP.

**THE HAND-MADE TERRACOTTA** IS ACHIEVED BY USING DIFFERENT APPROPRIATE REFINED CLAY SOILS WHOSE CHARACTERISTICS ARE ONLY PRESENT IN THE REGIONS OF CENTRAL AND NORTHERN ITALY. THANKS TO THE TRADITION AND TO THE SECRETS OF SEVERAL GENERATIONS OF ITALIAN CRAFTSMEN THAT MAKES IT POSSIBLE TO PROVIDE, IN ITALY ONLY, THE BEAUTIFUL COLOURS WHICH VARIES CONSIDERABLY AND ARE USED FOR THIS COLLECTION:

- LIGHT GRAY, BLACK, CHOCOLATE, KHAKI, LIGHT BEIGE AND THE RED ONE RECYCLED FROM THE DEMOLITION/RENOVATION OF OLD HOUSES

THE HAND-MADE TERRACOTTA, A TYPE OF EARTHENWARE THAT IS AVAILABLE IN NATURE, IS FORMED TO THE DESIRED SHAPE BY PLACING THE CLAY-BASED BODY INTO A WOOD TILE AND LET IT DRY NATURALLY.

ONCE THE TILES BECOME EASY TO HANDLE THEY ARE PLACED IN A KILN AND THEN FIRED WITH PRODUCTION CYCLE OF ABOUT 10 DAYS; THIS PROCEDURE IS NEEDED TO AVOID BREAKAGE OF THE TILES.

THEY ARE THEN CUT INTO THICKNESS AND CUT OUT BY HAND OR BY WATERJET PROCEDURE

**THE BARBIERI FAMILY ARTISANS**, SINCE 1975 IS AN ETERNAL QUEST FOR PERFECTION IN AMUSING WAY WITH MARBLE.

THE QUALITY OF THEIR HAND-MADE WORK COMBINED WITH THE QUALITY OF GIOVANNI BARBIERI'S DESIGN IS NOW ARRIVE TO OFFER AN INCOMPARABLE SUPERIOR ALTERNATIVE ON ALL BACKLIT ONIX, SEMIPRECIOUS STONE STONE CONCEPTS WALL AND FLOOR SOLUTIONS BY OFFERING AN UTTERLY UNIQUE AESTHETIC AVAILABLE IN INFINITIVE VARIETY OF COLOURS, PATTERNS AND DIMENSIONS.

MURANO COLLECTION IS SUGGESTED TO BE INSTALLED ON INTERIORS BY AVOIDING INTERIOR SHOWER WALLS AND SIMILAR AREAS, ONLY.

THEY ARE SUPPLIED INSTALLED ON TEMPERED OR STRATIFIED GLASS ALSO SUITABLE FOR SMALL SIZES WITH LED BACKLIT SYSTEM INCLUDED EVENTUALLY.

# THE MURANO COLLECTION

IS AWARD WINNER OF



THIS PRESTIGIOUS AWARD IS GIVEN BY THE MOST RENOWNED AMERICAN MAGAZINE CALLED INTERIOR DESIGN .

- ON DECEMBER 3, 2015 NEARLY 1,000 PEOPLE FROM THE DESIGN COMMUNITY (DESIGNERS AND MANUFACTURERS) GATHERED AT THE STATE-OF-THE-ART FRANK GEHRY DESIGN, IAC BUILDING IN NEW YORK CITY
- THE AUDITORIUM WAS STANDING ROOM ONLY, AS THE WINNERS WERE ANNOUNCED LIVE BY HOSTS CINDY ALLEN, EDITOR IN CHIEF, AND CAROL CISCO, PUBLISHER
- THIS YEAR, THE BEST OF YEAR AWARDS CELEBRATED ITS 10TH ANNIVERSARY AND HAD OVER 300 SUBMISSIONS FOR THE BEST IN 10 CATEGORIES, CELEBRATING THE BEST IN DESIGN FROM THE PAST DECADE
- THERE WERE OVER 1,800 ENTRIES IN 142 CATEGORIES. NEARLY 60,000 VOTES WERE CAST FOR PRODUCT BY THE A+D INDUSTRY.

## SUGGESTED DESTINATION USE:

- MAIN ENTRANCE DECORATIVE PANEL RESIDENTIAL-COMMERCIAL
- BOUTIQUE, RESTAURANT, LUXURY HOTEL LOGO
- BATHROOM DECORATIVE PANEL  
(SUITABLE IN LOW HUMIDITY AREA, NOT INSIDE A SHOWER).
- LOUNGE BAR - RECEPTION COUNTER.

NOT FOR EXTERIOR USE.

### ACCESSORIES:

- LED BACKLIT SYSTEM FOR HUMIDITY ARE DESTINATION USE ALSO.
- REMOTE CONTROL DIMMER FOR ANY LED BACKLIT DENSITY REGULATION.
- METAL FRAME FOR INSPECTION / LED REPLACEMENT FROM THE FRONT OR FROM THE BACK SIDE OF THE PANEL
- STAINLESS STEEL STIRRUP ALREADY INCLUDED IN THE TEMPERED GLASS BACK SUPPORT AND NOT VISIBLE IN THE FRONT, FOR INSTALLATION OF THE MURANO PANEL DETACHED FROM THE WALL.

WE WILL BE HAPPY TO HELP YOU DESIGN AND PRODUCE YOUR PROJECT  
IN THE BEST WAY YOU COULD DESIRE,  
EVEN FOR A UNIQUE EXCLUSIVE DESIGN AND CUSTOM MADE SINGLE PRODUCTION FOR YOU,  
ONLY.

## SAINT GERMAIN

CARRARA, CALACATA AND THALA GREY  
MARBLE WITH WHITE SILK AND OPALINE  
MURANO GLASS POLISHED RELIEF INLAY

PANEL SIZE 38" x 38"  
(CM 96 x 96 x 2)

FOUSSANA MARBLE, BROWN UMBRIA HAND-MADE TERRACOTTA WITH  
DARK GREY MURANO GLASS POLISHED RELIEF INLAY

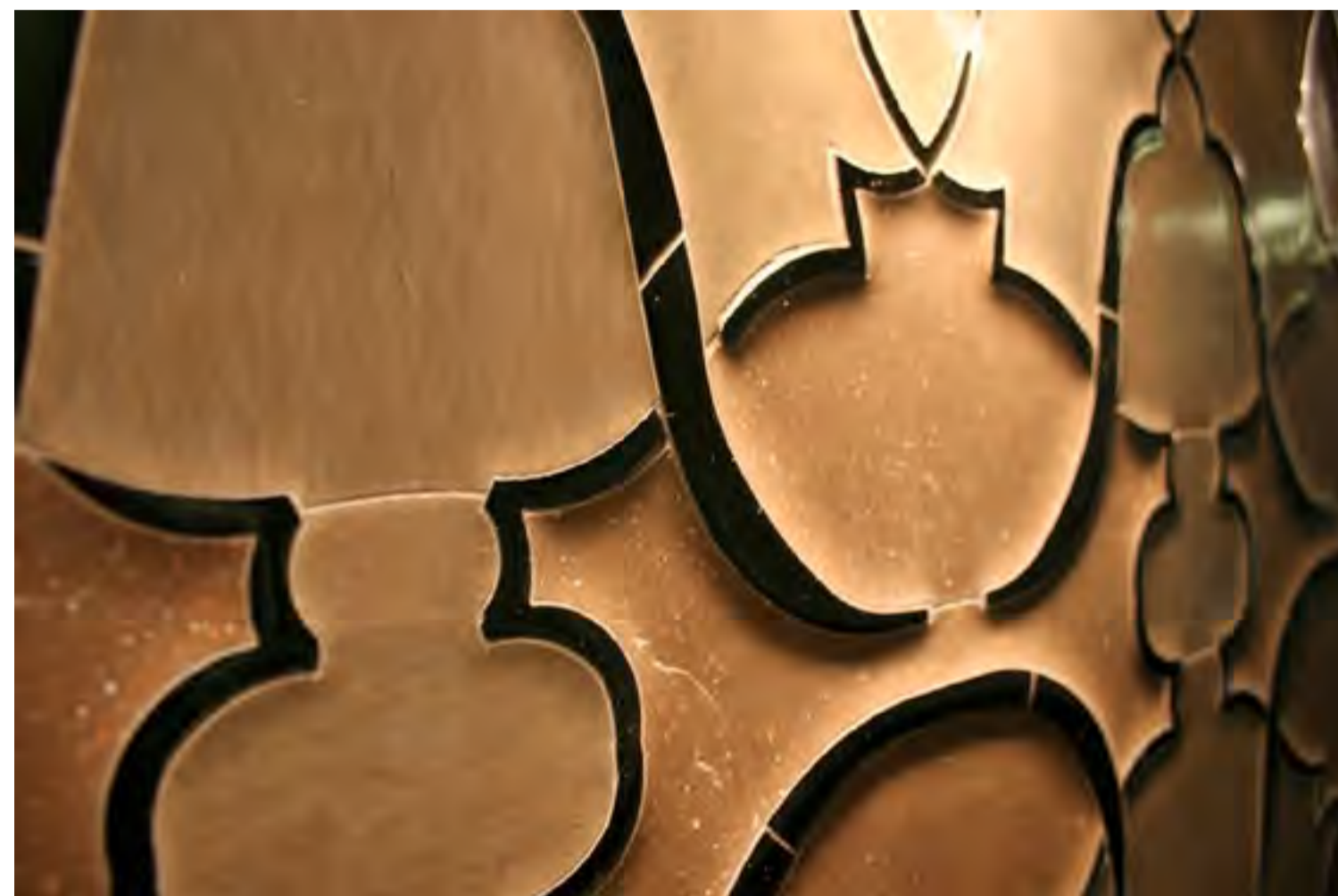

BACKLIT OFF

BACKLIT ON

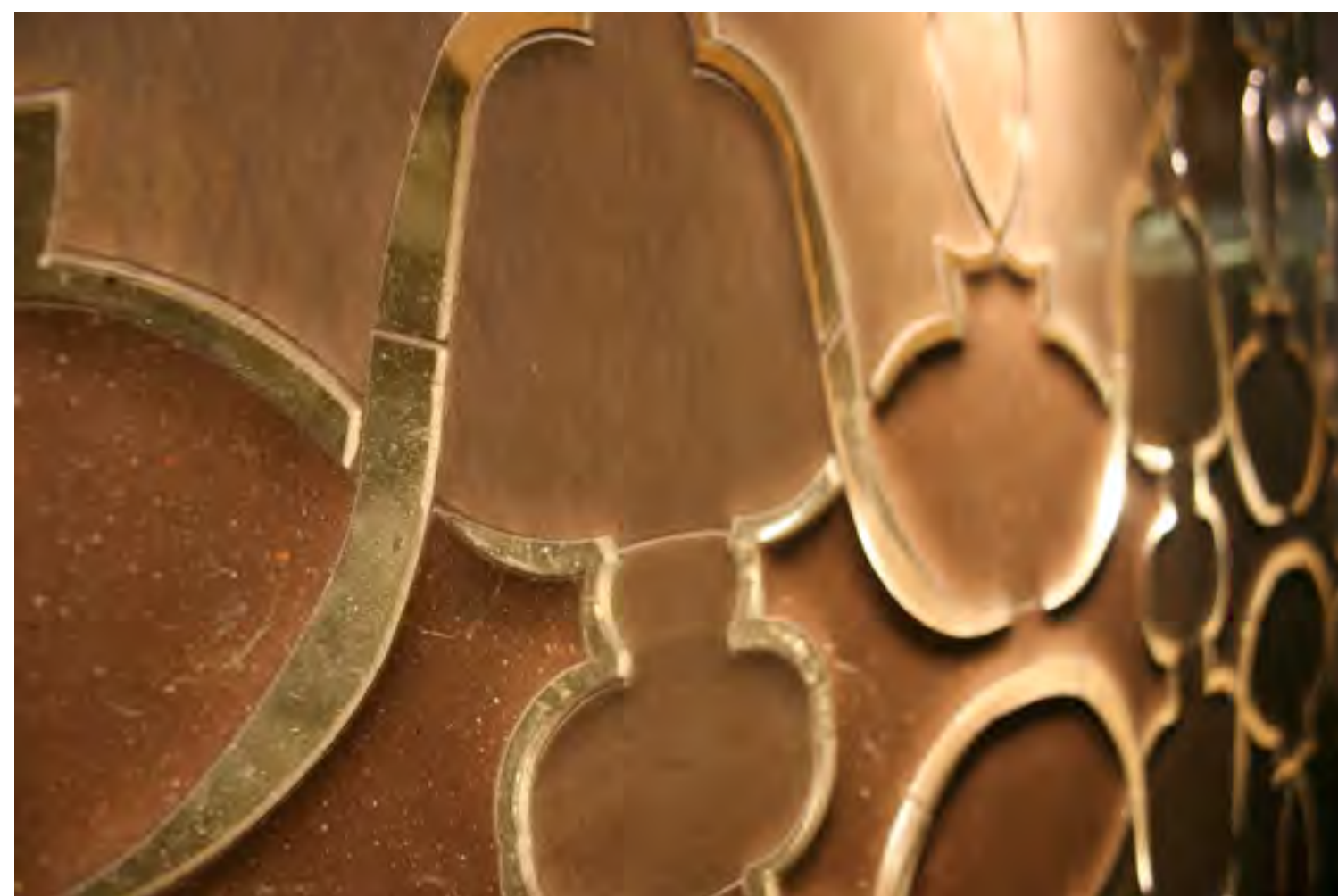

## SAINT GERMAIN

BLACK AND GREY TUSCANY HANDMADE TERRACOTTA  
WITH MURANO GLASS POLISHED RELIEF INLAY

PANEL SIZE 38" x 80"  
(CM 96 x 200 x 2)



GREY AND BLACK TUSCANY HAND-MADE TERRACOTTA WITH  
DARK GREY MURANO GLASS POLISHED RELIEF INLAY (HALF PANEL BACKLIT)



# OBLIO

GREY AND BLACK UMBRIA/  
TUSCANY HAND - MADE TERRACOTTA  
WITH POLISHED RELIEF INLAY IN DARK GREY  
MURANO GLASS ( WHITE WHEN BACKLIT ).  
PANEL SIZE 38" X 38" ( CM 96x96 )

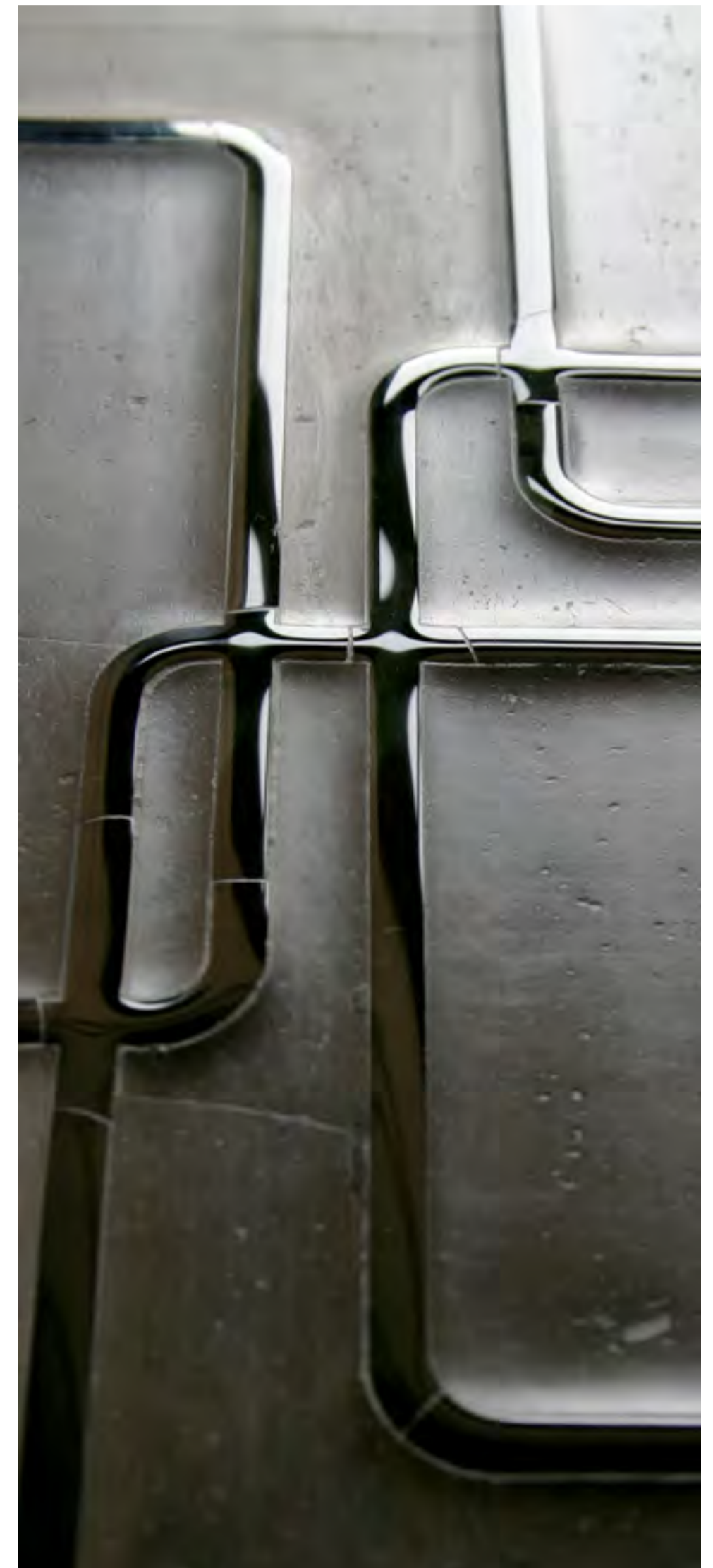



## CLAS

CM 15X25 MODULAR SHAPES OR FIT TO SIZE

BROWN/GREY HANDMADE TERRACOTTA &  
FOUSSANA, THALA GREY, BEIGE AVORIO MARBLE  
DARK GREY MURANO GLASS  
THAT BECOME MOSTLY WHITE WHEN BACKLIT

MIXED SURFACE TEXTURES HONED/ POLISHED  
PANEL SIZE 38" x 38" (CM 96 x 96 x 2)





**HEX**  
GREY AND BLACK UMBRIA/TUSCANY HAND - MADE TERRACOTTA  
WITH POLISHED RELIEF INLAY IN DARK GREY  
MURANO GLASS (WHITE WHEN BACKLIT).  
PANEL SIZE 38" x 38" (CM 96x96)







# FLORA

LIGHT BEIGE UMBRIA HAND - MADE TERRACOTTA  
WITH BIANCO ANTICO MARBLE AND  
POLISHED RELIEF INLAY IN WHITE SILK  
MURANO GLASS





SIN

BLACK UMBRIA HANDMADE TERRACOTTA WITH  
BLUE COBALT & DARK GREY MURANO GLASS  
POLISHED RELIEF INLAY

PANEL SIZE 38" X 38" ( CM 96X96 )

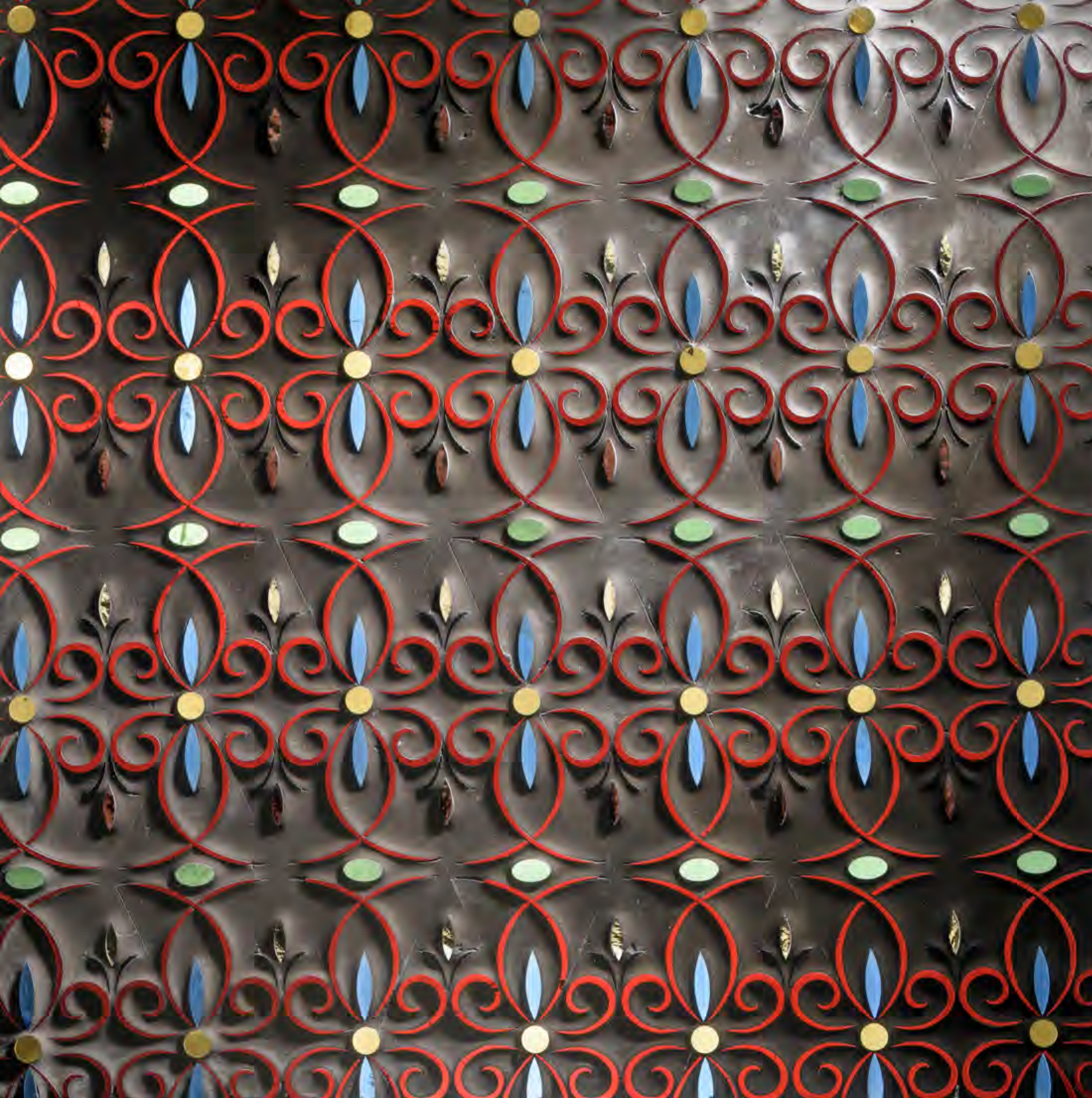

TEFI

GREY UMBRIA HAND-MADE TERRACOTTA,  
WITH 8 DIFFERENT MURANO GLASS POLISHED RELIEF INLAY.  
PANEL SIZE 38" x 38" ( CM 96 x 96 x 2)

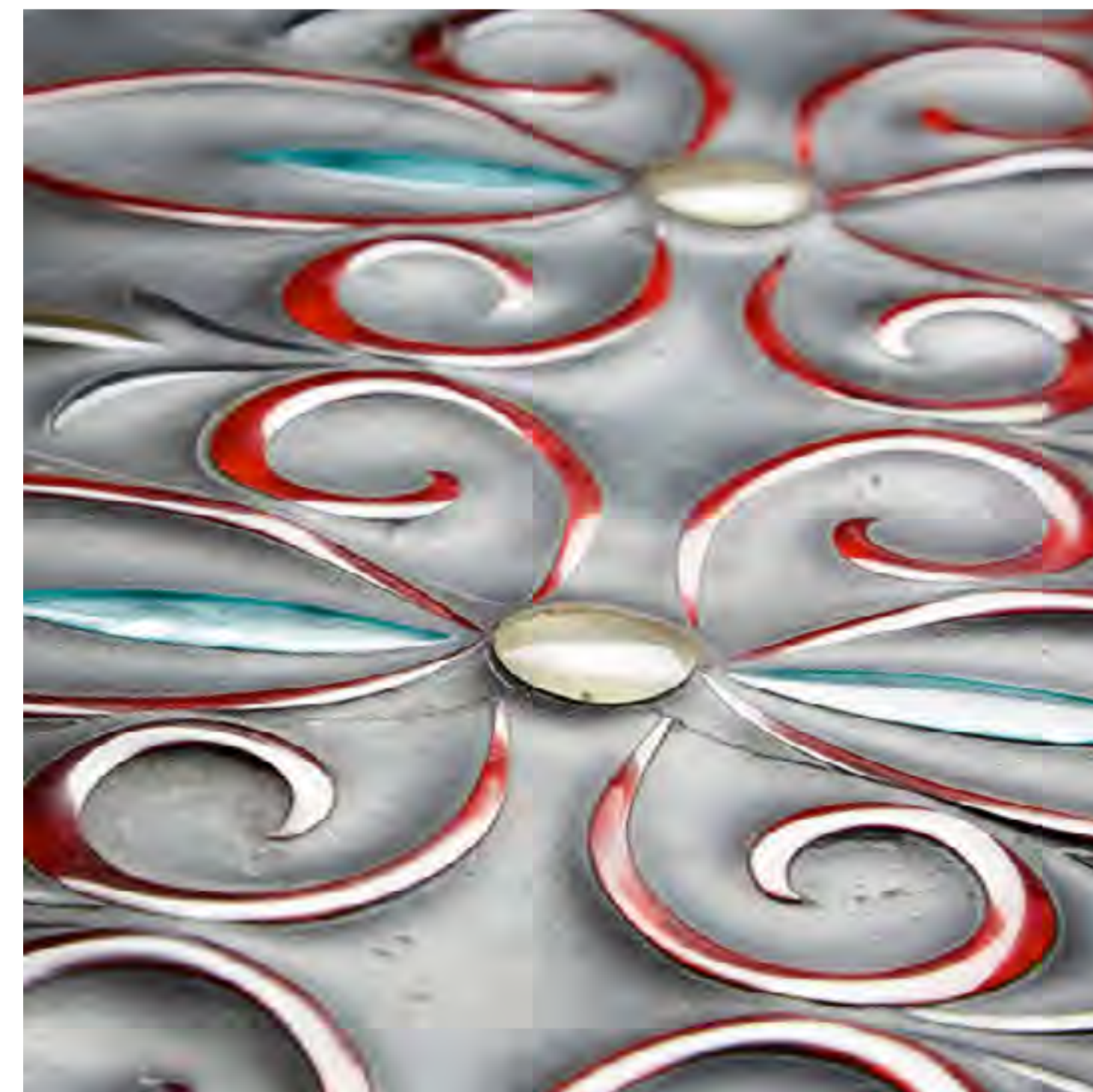

# HERAMOSA

RED TRAVERTINE,  
RED RECLAIMED VENETIAN HANDMADE TERRACOTTA,  
AMBER MURANO GLASS POLISHED RELIEF INLAY  
WITH GOLD LEAF DOT INSERT  
PANEL SIZE 38" x 38" ( CM 96 x 96 x 2)



BACKLIT



SURFACE LIGHTING ENHANCING THE RELIEF



LIGHT BEIGE AND KHAKI UMBRIA HAND-MADE TERRACOTTA, AVORIO MARBLE & WHITE SILK MURANO GLASS POLISHED RELIEF INLAY

LIGHTING ENHANCE RELIEF SURFACE



FULL BACKLIT



BLACK HAND-MADE TERRACOTTA /WHITE SILK MURANO GLASS

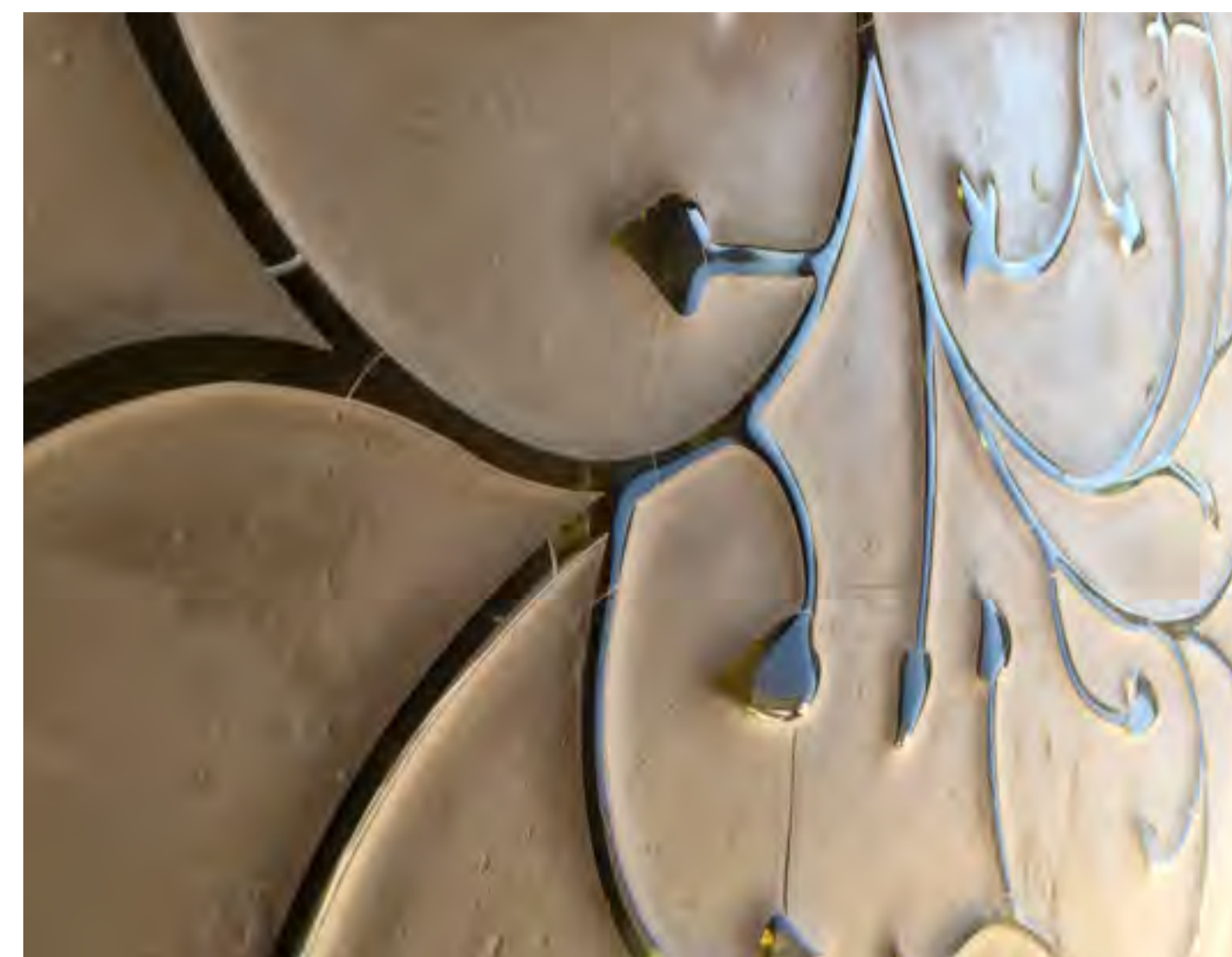

KHAKI HAND-MADE TERRACOTTA, & AMBER MURANO GLASS POLISHED RELIEF INLAY.





GREY UMBRIA HAND-MADE TERRACOTTA, & POLISHED RELIEF INLAY WITH TRANSPARENT GLASS & SILVER LEAF APPLIED ON THE BOTTOM ON EACH SINGLE PIECE.



GREY UMBRIA HAND-MADE TERRACOTTA, WITH RED RUBIN MURANO GLASS POLISHED RELIEF INLAY

GIOVANNI BARBIERI JUNI 2011





## INSTALLATION OPTIONS



WE HELP TO SUGGEST HOW TO INSTALL ON NICHE,  
AT SAME WALL SURFACE LEVEL AND DETACHED FROM THE WALL

## INSTALLATION DETACHED FROM THE WALL



WE CAN SUPPLY STAINLESS STEEL STIRRUP ALREADY INCLUDED IN THE TEMPERED GLASS BACK SUPPORT BUT NOT VISIBLE IN THE FRONT, FOR DETACHED FROM THE WALL INSTALLATION MAXIMUM 13 CM AND IN REFERENCE TO THE PANEL DIMENSION.

IN THIS CASE, THE MURANO PANEL EDGE HAVE INCORPORATED A THIN ALLUMINIUM FRAME THAT IS FINISHED TOGETHER THE SURFACE IN THE WAY IT FOLLOW PERFECTLY THE WAVY THICKNESS PERIMETER EDGE OF THE PANEL.

# ART WORK

IN COOPERATION WITH  
ROBERTO LANARO METAL SCULPTOR

A PRICELESS HONOR

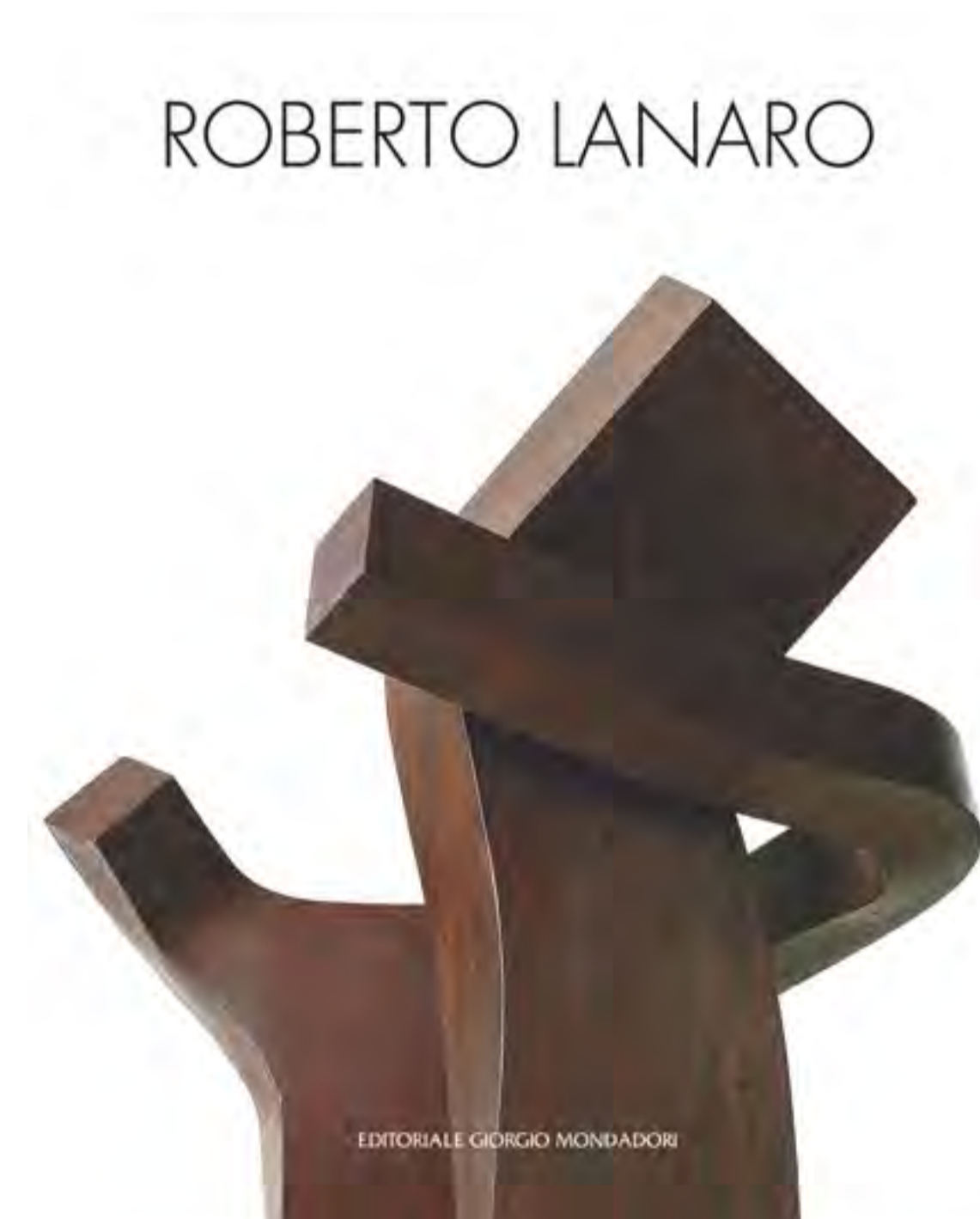

[WWW.ROBERTOLANAROSCULTORE.IT](http://WWW.ROBERTOLANAROSCULTORE.IT)

“WORKS OF ART ARE MIRRORS  
IN WHICH EVERYONE SEES THIS REFLECTED  
THAT RESEMBLES HIM “

COSTANTIN BRANCUSI



“SINUOSITY (DOTS) “  
24” x 24” x 3/8 (CM 61 x 61 x 1).  
BRASS AND NATURAL STONE HANDMADE  
12 PIECES LIMITED EDITION



“CORE”  
DIAMETER 24” x 3/8 (CM 61 x 1).  
BRASS AND NATURAL STONE HANDMADE  
12 PIECES LIMITED EDITION

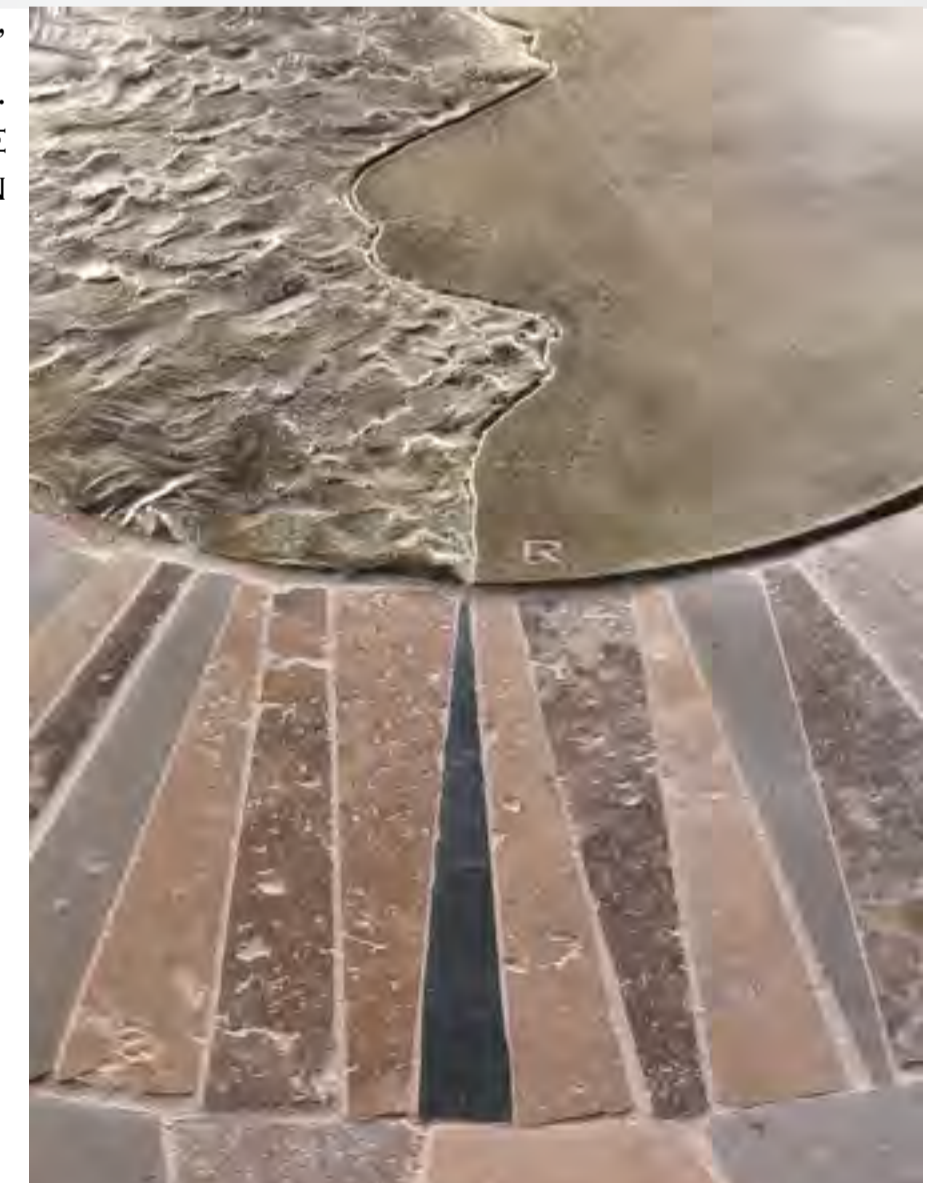



"FRAMENTI SINUOSITY"  
24" x 24" x 3/8 (CM 61 x 61 x 1).  
STAINLESS STEEL AND  
8 DIFFERENT CARRARA - CALACATTA MARBLE  
12 PIECES LIMITED EDITION



"CONJUNCTION"  
24" x 24" x 3/8 (CM 61 x 61 x 1)  
BRASS AND  
8 DIFFERENT YELLOW-BEIGE  
NATURAL STONE  
12 PIECES LIMITED EDITION



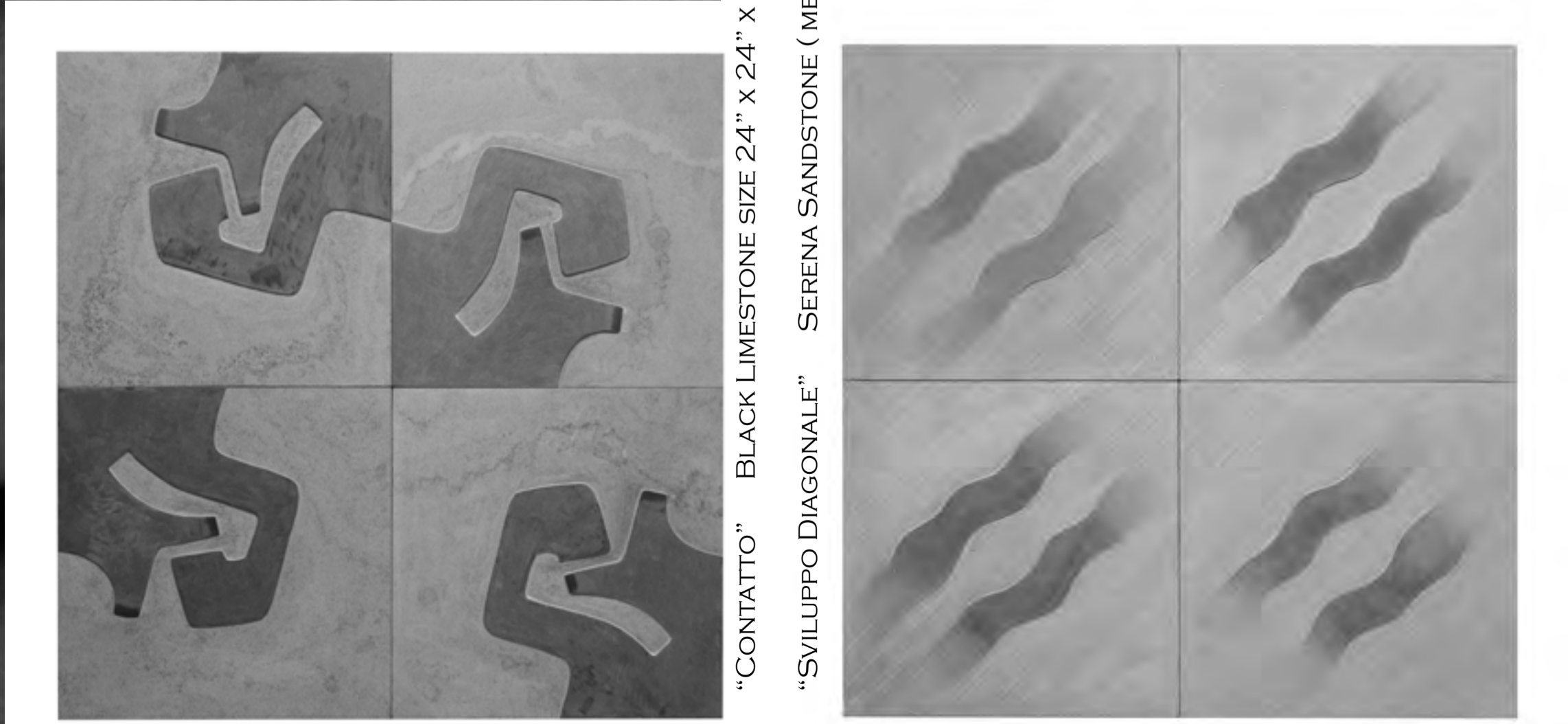

"CONTATTO" BLACK LIMESTONE SIZE 24" X 24" X 3/4 (CM 61 X 61 X 2) 12 PIECES LIMITED EDITION

"SVILUPPO DIAGONALE" SERENA SANDSTONE (MEDIUM LIGHT GREY) SIZE 24" X 24" X 3/4 (CM 61 X 61 X 2) 12 PIECES LIMITED EDITION





“TRAMA CONTINUA” STAINLESS STEEL SIZE 24” X 24” X 2/8 (CM 61 X 61 X 0,5)





# POP ART

FOR

## ROMERO BRITTO

[WWW.BRITTO.COM](http://WWW.BRITTO.COM)

WORLD RENOWNED POP ARTIST USE HIS OPTIMISTIC ART  
TO SPREAD CHEER AND AWARENESS.



"LOVE" BY ROMERO BRITTO

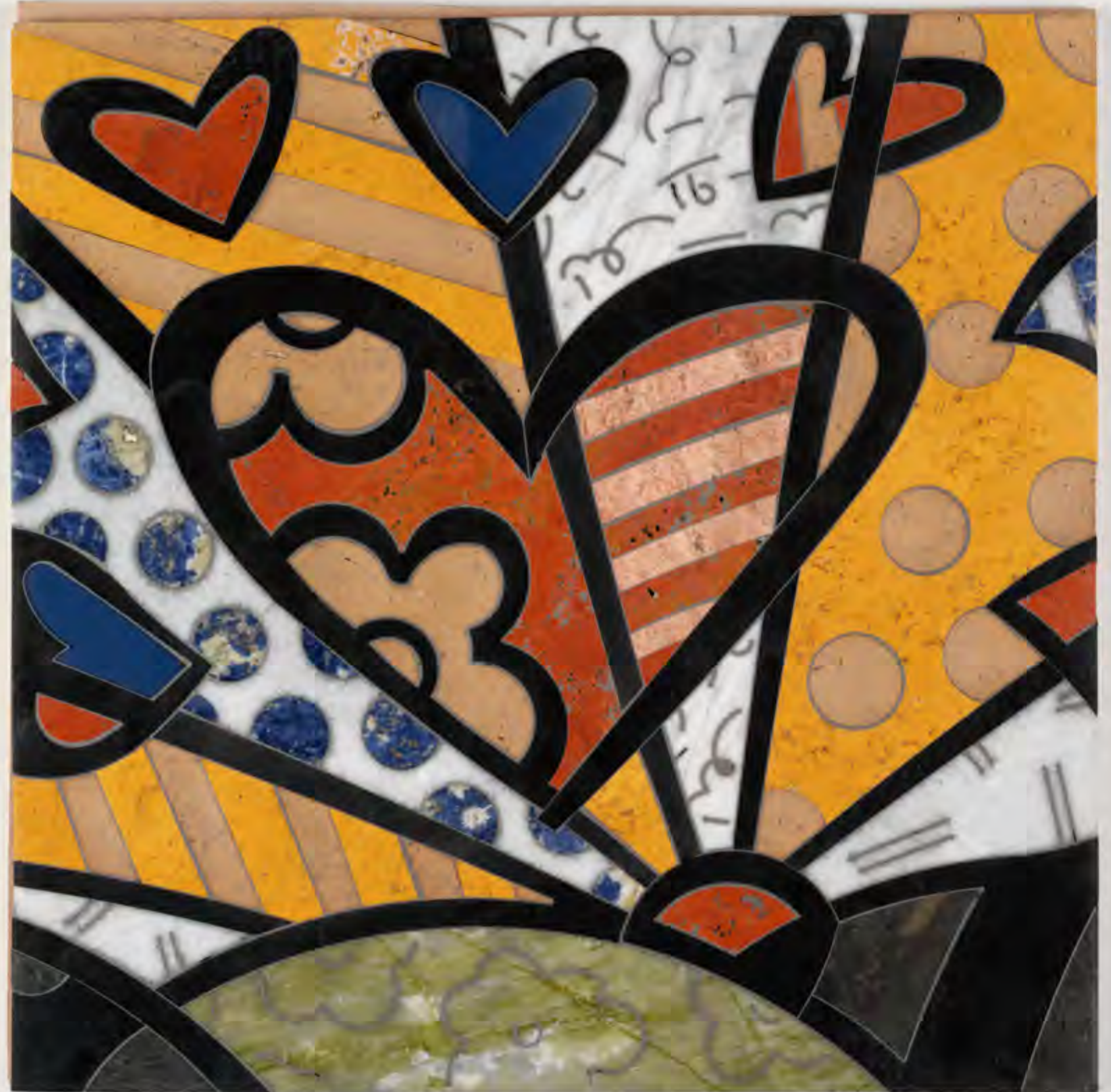

MURANO GLASS, HANDMADE TERRACOTTA, NATURAL STONE. SIZE 24" x 24" x 3/8,  
SOLD ON LINCOLN ROAD STORE IN MIAMI SOUTH BEACH.  
BY ARTIST ACCORDING, ONLY.

# BIOGRAPHY

GIOVANNI BARBIERI STARTED HIS CAREER AT THE AGE OF 14 BY OPERATING IN THE MARBLE SECTOR AS A GO-GETTER. WHEN HE WAS 16 YEARS OLD HE WAS CAPABLE OF COMPLETING INDEPENDENTLY FLOORINGS WITHIN HIS OLDER BROTHER'S BUSINESS.

IN 1984, AT THE AGE OF 18, GIOVANNI CONTRIBUTED 50% OF THE INVESTMENT ENTERING INTO BUSINESS PARTNERSHIP WITH HIS BROTHER BY ESTABLISHING F.LLI BARBIERI. IN THOSE DAYS THE COMPANY HAD ALREADY BEGUN TO PRODUCE TUMBLED MARBLES FOR ITS OWN REALIZATIONS.

SUBSEQUENTLY, AT THE AGE OF 22, GIOVANNI STARTED TO TAKE CLASSES FOR INTERIOR DESIGN BY COMPLETING SUCCESSFULLY 2 THREE-YEAR-COURSES BETWEEN 1989 AND 1997. DURING THAT TIME THE BEST RESULTS WERE ACHIEVED IN THE BUILDING SITE /PROJECTS IN COLLABORATION WITH THE ARCHITECTS THAT WERE TEACHING THE CLASSES.

THESE COLLABORATIONS ENHANCED A PERIOD OF STRONG PROGRESSION IN WHICH GIOVANNI WAS THE SOLE DEVELOPER OF THE PROJECTS AND THE ONLY SUPPLIER OF MARBLE TILES DERIVING EXCLUSIVELY FROM THE FAMILY STONE BUSINESS. HE ALSO PERSONALLY REALIZED AND/OR SUPERVISED EVERY INSTALLATION TO ENSURE THE SATISFACTION OF THE FINAL CUSTOMERS. LATER THE FOCUS WAS LAID ON THE PRODUCTION PROCESS OF NEW PRODUCTS; INITIALLY FOR THE LOCAL MARKET THEN EXPANDING ALL THE WAY TO THE UNITED STATES, THANKS IN PARTICULAR TO THE EXCELLENT DESIGN UNDERSTANDING IN RESEARCH & DEVELOPMENT AS WELL AS THE MARKETING OF HIS PRODUCTS THROUGH AMERICAN DISTRIBUTORS.

MANY PATENTS HAVE BEEN DEVELOPED TOWARDS THE END OF '90S SUCH AS DECORATION METHODS AND THOSE PERTAINING TO INDUSTRIAL PROCEDURES. WITHOUT DOUBT THE MOST IMPORTANT DEVELOPMENTS HAVE BEEN THE NATURAL STONE TILES SURFACE FINISHING CALLED "MARMO ANTICO LUCIDO" ; "FRAMENTI BORDERS COLLECTION" ; "TIMEWORN MARBLE" AND THE "SERIE STORICA".

THE TRADE SHOW BOOTHS WHICH WERE EXPLICITLY DESIGNED AND BUILT BETWEEN 1999 AND 2002 WERE PROMPTLY SOLD TO CUSTOMERS FOR THEIR OWN NEW SHOWROOMS. THE SUCCEEDING SHOW BOOTHS WERE EACH TIME IMPROVED IN QUALITY AND AESTHETIC.

GIOVANNI PARTICIPATED IN SOME CONTEMPORARY ART COMPETITIONS RECEIVING A SPECIAL MENTION IN TORINO IN 2003 BY PRESENTING SOME EXCLUSIVE DECORATIVE PANELS, WHICH WERE CREATED IN COLLABORATION WITH ROBERTO LANARO.

IN 2008 HIS NEW CREATIONS OF PRODUCTS AND COLLECTIONS WERE WELL RECEIVED, NOT ONLY IN THE AMERICAN MARKET. ONE OF THE BEST NEWS IN THAT YEAR WAS SURELY "AMBRA COLLECTION" THAT HAD RECEIVED ONE OF THE 2008 AMERICAN ARCHITECTURE AWARDS THROUGH "ARCHITECTURAL RECORD" MAGAZINE WHICH DESIGNATED "AMBRA COLLECTION" AMONG ONE OF THE 8 BEST 2008 CONSTRUCTION PRODUCTS IN USA. AMBRA COLLECTION WAS EXPOSED AT "TRIENNALE DESIGN MUSEUM" IN MILAN FOR MORE THAN ONE YEAR.

IN 2010 GIOVANNI STARTED HIS SUCCESSFUL COLLABORATION WITH SARA BALDWIN DEVELOPING TIMEWORN MOSAICS. ENGINEERED 3D MARBLE TILES COLLECTIONS: EXCITON/ HIVE TOGETHER THE FIRST PORCELAIN TILE MEMENTO COLLECTIONS ARE HONOREE AND AWARD WINNER ON BEST OF YEAR INTERIOR DESIGN USA IN 2013.

GIOVANNI BARBIERI HAS BEEN A SOURCE OF INSPIRATION FOR MANY RENOWNED BRANDS AND COMPETITORS RESULTING IN THE SUCCESSFUL REPRODUCTION OF HIS INVENTIONS AND TECHNIQUES.

2014 IS LONDON SURFACE DESIGN AWARD WINNER WITH CARVED COLLECTION "CLAS" ON BELGIUM PROJECT . THE TILES DEVELOPED ARE INCREASING FOR THEIRS BRAND IN THE MEANTIME.

2015 IS THE YEAR OF MURANO COLLECTION, AWARD WINNER AT BEST OF YEAR INTERIOR DESIGN, NYC, USA.

2016 THE MOST ADVANGARDE 3D WALL COLLECTION BECOME REAL FINALLY THANKS STONE SOURCE USA WHERE THE WORLD'S FIRST 3D PORCELLAIN TILE COLLECTION " TRILOGY" IS AWARD WINNER AT BEST OF YEAR INTERIOR DESIGN, IN USA AND NEW YORK CITY DESIGN AWARD ON LAST MAY 20TH 2017 AT MOMA IN NYC.

2017 GIVING START TO NEW COOPERATION WITH OTHER 3D WALLS MANUFACTURER BETWEEN EUROPE AND USA. "- RR- COLLECTION " IS THE LATEST ONE CREATION ALSO. GIOVANNI BARBIERI DESIGN AND PRODUCTS ARE JUST INTRODUCED IN AUSTRALIA/NEW ZEALAND , INDIA AND USA BY NEW SELECTED ENTHUSIAST PARTNERS. AUGUST FINALLY AFTER LONG TIME R & D GIVING BORN TO "SOPHISTICATED SIMPLICITY" A TRUE REVOLUTIONARY AVANT-GARDE WAY TO CREATE PATTERNS SIMPLY USING STANDARD TILES OBTAINING ALWAYS SOPHISTICATED DIFFERENT SHAPES AND CONSEQUENTLY UNIQUE AESTHETICAL RESULT.

"2018 STARTING WITH NEW ANTIQUED TILES COLLECTION GENUINE REPRODUCING ANTIQUED HANDMADE TERRACOTTA TILES: FINALLY A NEW BLACK FLOOR DEVELOPED ESPECIALLY TO OFFER EASY CLEANING AND MAINTENANCE SURFACE DUE TO ITS TIMEWORN SURFACE AND OLD LOOK, SIZES DEVELOPED ARE SUITABLE FINALLY NOT ONLY FOR TRADITIONAL HOUSES , BUT ESPECIALLY FOR MINIMALIST INTERIOR DESIGN STYLE CONCEPTS WHICH GIOVANNI BARBIERI STRONGLY BELIEVE THE MARKET NEED.

## GIOVANNI BARBIERI

AN ETERNAL PERSUIT OF PERFECTION AMUSING WITH MARBLE.

SINCE 1979,  
ARTISAN / INSTALLATOR  
&  
PROJECT ASSISTANT / MANUFACTURER / SUPPLIER

SINCE 1996  
TILE & STONE DESIGN STUDIO

WWW.GIOVANNIBARBIERI.COM

Giovanni Barbieri  
Schiavon, Vicenza, Italy. [info@giovanibarbieri.com](mailto:info@giovanibarbieri.com)



BEST OF YEAR 2013



SURFACE DESIGN AWARDS WINNER