



I CONCI® | BAGNO

I CONCI[®] | BAGNO



Linee essenziali, calore dei materiali, attenzione al dettaglio e ottimale gestione degli spazi per realizzazioni progettuali su misura.

La Collezione su misura I Conci Bagno esprime equilibrio formale tra estetica, esigenze quotidiane e il desiderio di comodità abitativa e funzionale.

I Conci oggi, con la sua Collezione su misura si riafferma per continuità e design, benessere ed esclusività e qualità esecutive indiscutibili.

Essential design, warm materials, an eye for detail and an excellent use of the space available are the main features of our tailored projects. The Custom Collection I Conci Bagno is a perfect example of formal balance between beauty, daily needs and a desire for comfort and functionality. Thanks to the Custom Collection, I Conci stands out once again for its consistency and excellent design, and for the unquestionable quality and exclusivity of its collections.

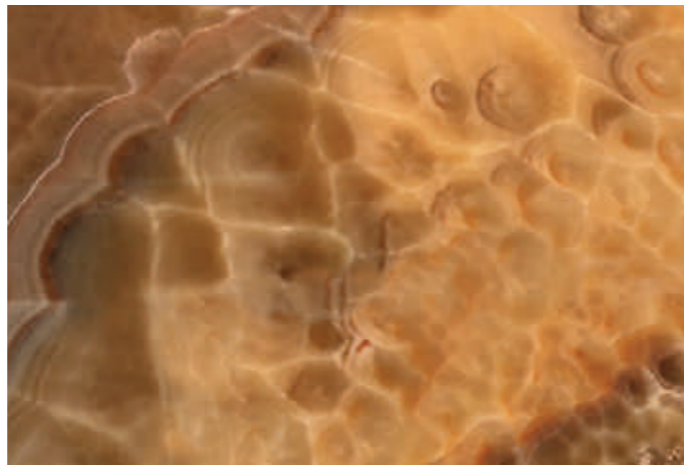
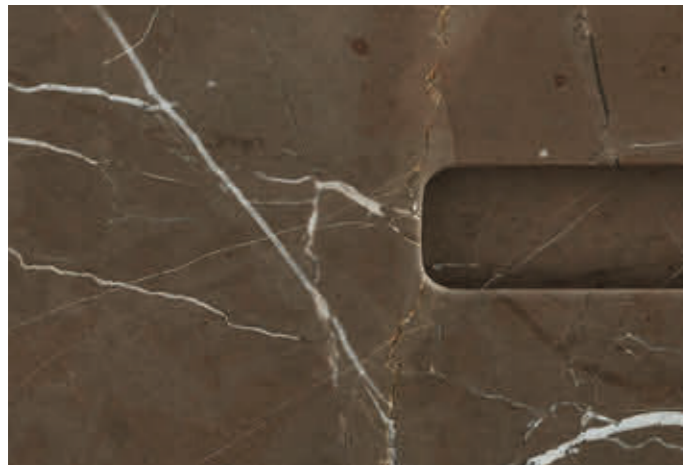

materiali

Il marmo è un materiale nobile, ricco e antico che integra in questa collezione le pietre, i laccati e le essenze legno in una ricerca formale destinata ad un design attivo per funzionalità, concretezza e libertà creative.

Nella nostra Collezione su misura, il marmo e le pietre utilizzate, si rivelano per bellezza prestandosi ad essere interpretate, immaginate, esaltate dai progettisti di domani.

Marble is a noble, rich and ancient material. In this collection, marble, stones, lacquered wood and many different kinds of wood join together and give life to extraordinary design items characterized by high functionality, solidity and creative freedom. In our Custom Collection, marble and stones express all their beauty: they are ready to be interpreted, imagined and sublimated by the designers of tomorrow.

artigianalità

Lavoro, esperienza, conoscenza da più di 40 anni. Il marmo conserva la sua inestricabile e primitiva bellezza prestandosi costantemente a nuove tecniche di taglio, incisione, lucidatura e infinite specialità operative.

La Collezione su misura I Conci Bagno custodisce ancora una volta il segreto di una rifinitura, celebra il dettaglio di una curva, perpetua la definizione di un assemblaggio.

Crea così nuove estetiche valorizzando il lavoro semplice, delicato e raro a realizzarsi delle lavorazioni artigianali fatte a mano.

Hard work, knowhow, over 40 years of experience. Our marble keeps its innate and primordial beauty while it is cut, carved and polished using the most advanced techniques.

The Custom Collection by I Conci Bagno treasures once again the secret of a finishing; it celebrates the detail of a curve; it perpetuates the definition of an assembly.

This collection creates new shapes and gives value to the simple, delicate and increasingly rare work that lies behind artisanal manufacturing.





In una goccia
d'acqua si trovano
tutti i segreti
degli oceani. [Khalil Gibran]

In one drop
of water are found
all the secrets
of all the oceans.

collezioni

lido	10
londra	22
nebula	34
basic	44
flair	48
ramis	52
manta	58
illumino	64

schede tecniche

lavabi	69
specchi	77
lampade	80
materiali	81

lido



Ambiente in marmo Calacatta Conci e Grigio Imperiale.
Mobile LIDO con doppio cassetto e top massello con lavabo centrale. Vasca NIAGARA in Calacatta Conci.

Setting in marble Calacatta Conci and Grigio Imperiale.
LIDO furniture with double drawer and massive washbasin with central basin NIAGARA bathtub in Calacatta Conci.



I CONCI | BAGNO



Particolare del mobile LIDO. Cassetto con anta in pietra alleggerita.
Materiale Calacatta Conci.

*Detail of LIDO furniture. Drawer with door covered in lightened stone.
Material Calacatta Conci.*





I CONCI ; BAGNO



Particolare del top massello con lavabo scavato.
Piletta in pietra ricavata dallo stesso elemento del top.

*Detail of massive washbasin with carved basin.
Waste in stone formed by the same element of the top.*



Vasca NIAGARA realizzata su misura,
in marmo Calacatta Conci.

*Custom NIAGARA Bathtub,
in marble Calacatta Conci.*

lido



Mobile LIDO con anta in Alpikord Walnut Groove e top Bianco S.Caterina. Parete rivestita in Bianco S.Caterina pettinato.

LIDO with door in Alpikord Walnut Groove and top in Bianco S.Caterina. Wall covered in brushed Bianco S.Caterina.



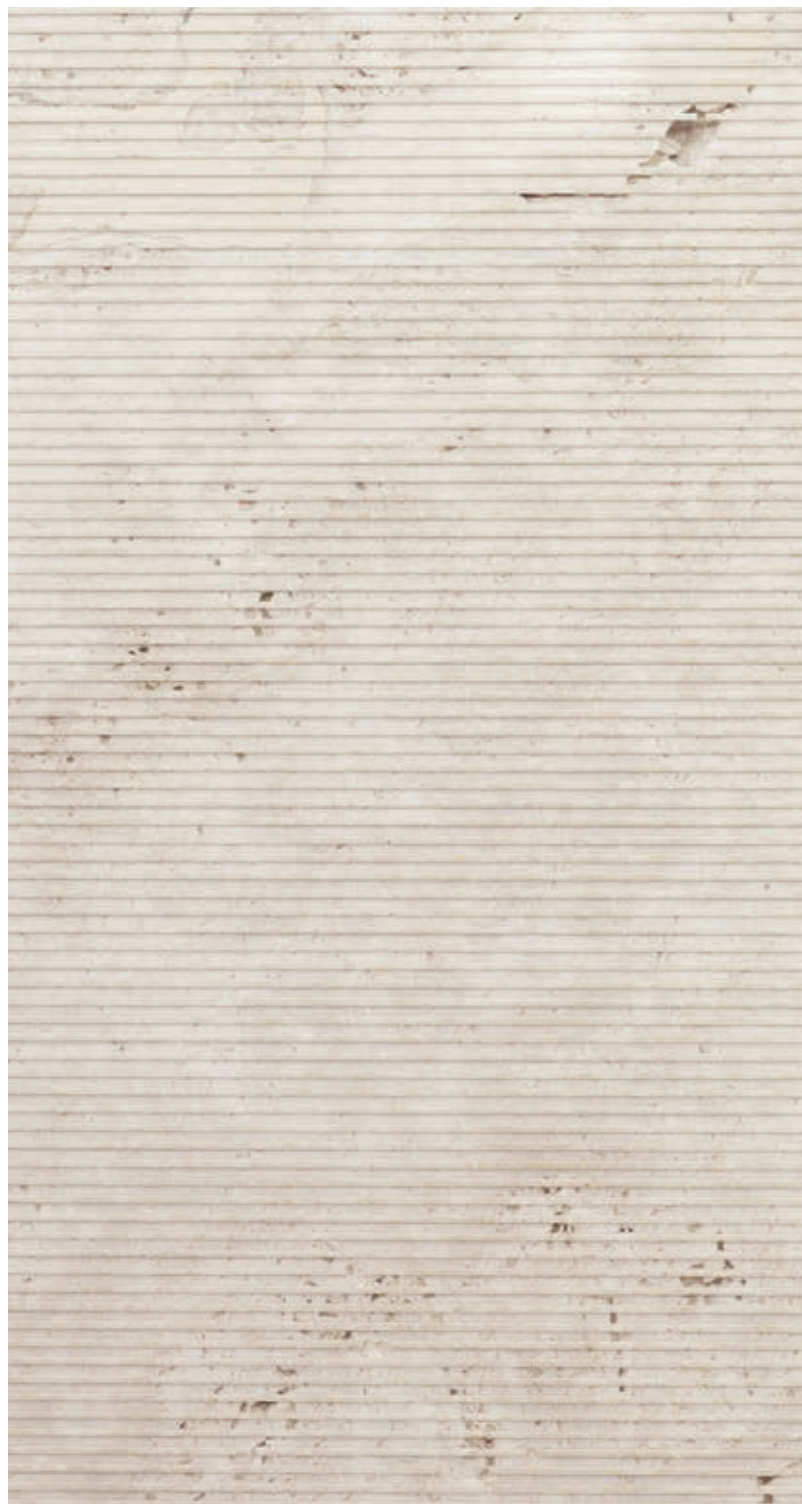

Particolare del top LIDO con lavabo assemblato.
Piletta in pietra ricavata dallo stesso elemento del top.
*Detail of LIDO's top with assembled washbasin.
Stone Waste formed by the same element of the top.*

londra



Mobile LONDRA, con fianco in Bianco S.Caterina e top in Onice Miele. Sistema contenitivo THE WALL parete con ante alleggerite in Onice Miele

LONDRA furniture with side in Bianco S.Caterina and top in Onice Miele. Containment system THE WALL with lightened door in Onice Miele.

I CONCI | BAGNO

Mobile LONDRA, particolare del fianco in Bianco S.Caterina.
Detail of LONDRA: side in Bianco S.Caterina.





Particolare del top massello con lavabo scavato in Onice Miele con vasca centrale.
Piletta in pietra ricavata dallo stesso elemento del top.
*Detail of massive top with assembled washbasin in Onice Miele with central basin.
Waste in stone formed by the same element of the top.*

londra



I CONCI | BAGNO

Ambiente LONDRA con mobile doppio cassetto e pavimento in Grigio Imperiale.
Rivestimento parete in marmo Bianco Statuario.

Setting LONDRA Piece of furniture with two drawers and floor in Grigio Imperiale.
Wall covered in Bianco Statuario marble.



Mobile LONDRA, particolare lavabo Grigio Imperiale con vasca assemblata.
Piletta in pietra ricavata dallo stesso elemento del top.
*Detail of LONDRA: washbain Grigio Imperiale with assembled basin.
Stone waste formed by the same element of the top.*



Vista del doppio mobile LONDRA con cassetti aperti che rivela un ampio contenimento interno.
Contenitori interni in finitura noce e metallo nero.

*View of double furniture LONDRA with open drawers that reveals a large storage space.
Internal containers in walnut and black metal finish.*



nebula

Ambiente in Travertino S.Caterina Venato poro aperto e marmo Pietra Brown.
Mobile NEBULA composto da due elementi contenitivi. Vasca SOFT scolpita da un unico blocco in marmo Pietra Brown.
*Setting in Travertino S.Caterina veined open pore and Pietra Brown marble.
NEBULA composed of two storage units. SOFT bathtub carved from a single block in Pietra Brown marble.*



Particolare della vasca in pietra massello del mobile NEBULA.
Piletta in pietra ricavata dallo stesso elemento del top.

*Detail of NEBULA's stone basin.
Stone waste formed by the same element of the top.*

Dettaglio della vasca scavata dal pieno in Pietra Brown.
Collezione SOFT.

*Detail of the bathtub carved from solid Pietra Brown stone.
SOFT collection.*





nebula

Mobile NEBULA con anta il legno Alpikord Light Grey Groove e top massello in marmo Sasso Rosso. Specchio Danubio. Pavimento in marmo Sasso Rosso e Bianco Carrara. Rivestimento parete in Bianco S.Caterina rigato.

NEBULA with wooden door in Alpikord Light Grey Groove and massive top in Sasso Rosso marble. Danubio Mirror. Marble floor in Sasso Rosso and Bianco Carrara. Wall covered in striped Bianco Santa Caterina marble.



Particolare della vasca del mobile NEBULA in marmo Sasso Rosso.
Detail of NEBULA's washbasin in Sasso Rosso marble.



Particolare del top mobile NEBULA
e dell'anta in legno Alpikord Light Grey Groove.

*Detail of NEBULA's top and wooden door
in Alpikord Light Grey Groove.*

basic

Ambiente con rivestimento in Cristallino Grigio e mobile BASIC con singolo cassetto in Fossena finitura fiammata. Piatto doccia BRENTA in Fossena.

Setting with Cristallino Grigio cladding and BASIC with single drawer in Fossena, with flaming finish. Shower tray BRENTA in Fossena.



Particolare anta e top.
Detail of door and top.



Particolare mobile BASIC in Fossena finitura fiammata con lavabo scatolato finitura painata e top cm.2
Detail of BASIC, in Fossena with flaming finish and assembled washbasin with matt finish and top cm 2.



flair



Ambiente con mobile FLAIR in Travertino S.Caterina Venato con doppio cassetto e fianco. Specchio con retroilluminazione led. Rivestimento parete in Travertino Titanio. Pavimento realizzato con doghe bicolore

Setting with furniture FLAIR in Travertino S.Caterina veined with double drawer and side. Mirror with led system light. Wall cladding in Travertino Titanio. Floor realized with bicolor staves.



Particolare del top massello con lavabo scavato in Travertino S.Caterina venato.
Piletta in pietra ricavata dallo stesso elemento del top.

*Detail of the massive top with assembled washbasin in veined Travertino S.Caterina.
Stone waste formed by the same element of the top.*



Particolare cassettera mobile FLAIR con ante in pietra alleggerita.

Detail of FLAIR chest of drawers, with doors covered in lightened stone.



Ambiente composto da mobile RAMIS realizzato con doppio cassetto con ante in marmo Calacatta Conci e finitura esterna in marmo Grigio Imperiale. Specchio ARNO realizzato a misura. Pavimento in Grigio Imperiale.

Setting composed of RAMIS with two drawers and Calacatta Conci marble doors. External finish in Grigio Imperiale marble. Custom ARNO Mirror. Grigio Imperiale marble floor.

ramis

Dettaglio lavorazione cornice a taglio inclinato 45°.

Detail frame processing inclined cut 45°.



Mobile RAMIS bicolore e top massello con due lavabi scolpiti dal pieno in Grigio Imperiale lucido.
Two-tone RAMIS and massive top with two basins carved in polished Grigio Imperiale.



manta

Mobile MANTA con doppio lavabo in Bianco S.Caterina e ante in legno Alpikord Walnut Groove. Pavimento 60x60 in Bianco S.Caterina.

MANTA with two basins in Bianco S.Caterina and wooden doors in Alpikord Walnut Groove. Floor 60x60 in Bianco S.Caterina.



I CONCI ; BAGNO

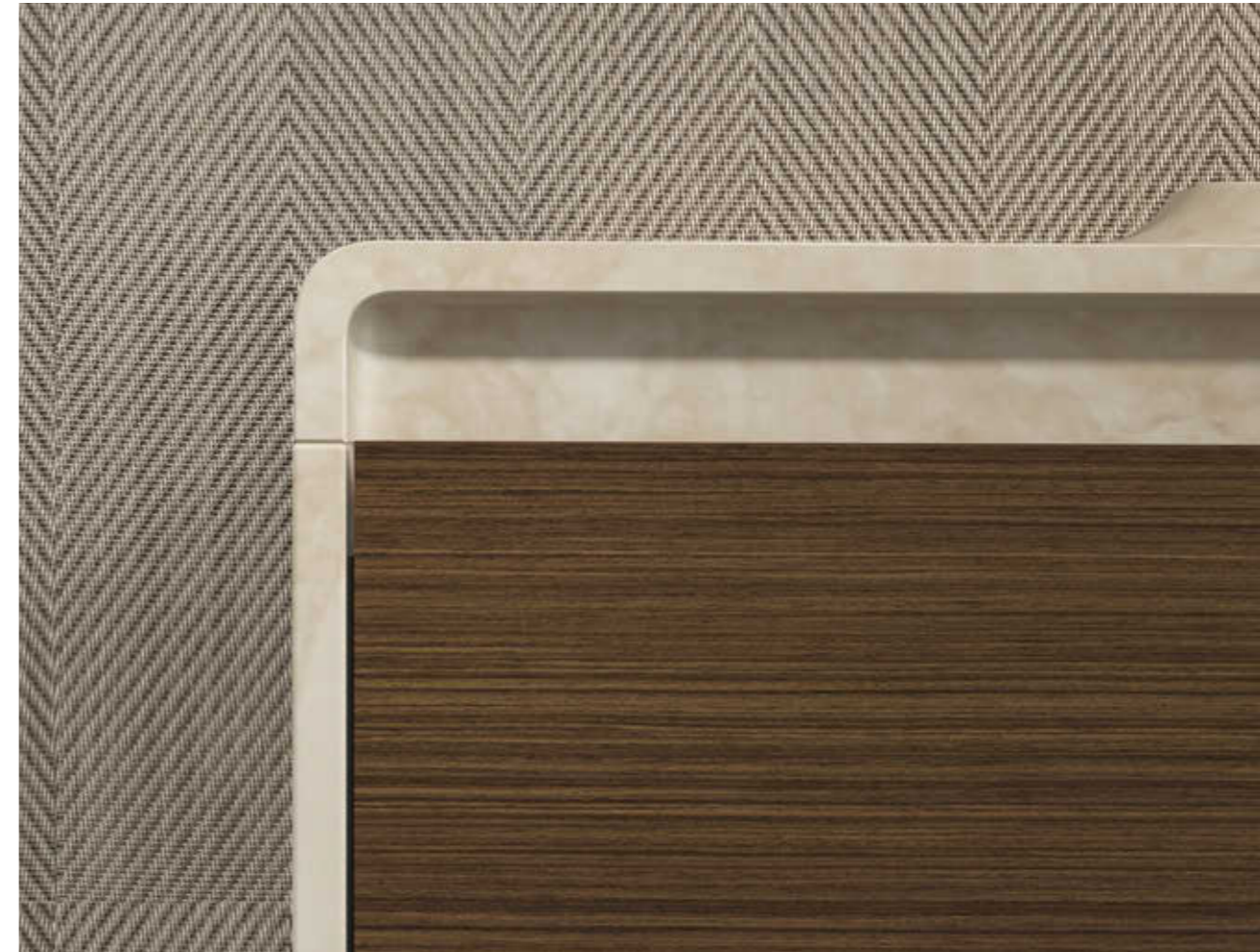

Dettaglio mobile MANTA con anta in legno Alpikord Walnut Groove e top in pietra.
Detail of MANTA with wooden door in Alpikord Walnut Groove and stone top.



Particolare del top con vasca scolpita in Bianco S.Caterina.
Piletta in pietra ricavata dallo stesso elemento del top.

*Detail of the top with carved basin in Bianco S.Caterina.
Stone waste formed by the same element of the top.*



Mobile ILLUMINO rivestito in Bianco S.Caterina. Ante e lavabo retroilluminati con led.
Lavabo assemblato con vasca massello in Onice Miele. Vasca massello modello NILO in Bianco S.Caterina.
Rivestimento parete e pavimento in Travertino Titanio. Specchio COLORADO.

*ILLUMINO covered in Bianco S.Caterina. LED-backlighted doors and washbasin.
Assembled washbasin with massive basin in Onice Miele. Massive bathtub NILO in Bianco S.Caterina.
Wall and floor cladding in Travertino Titanio. COLORADO Mirror.*



illuminino



Vista cassetto ILLUMINO con ampio contenimento interno. Contenitori interni in rovere e metallo bianco.
ILLUMINO drawer with large storage space. Internal containers in oak wood and white metal.



Particolare top mobile ILLUMINO con lavabo massello in Onice Miele scolpito e retroilluminato con led.
Detail of ILLUMINO's top with massive basin in Onice Miele carved and LED-backlighted.



lido

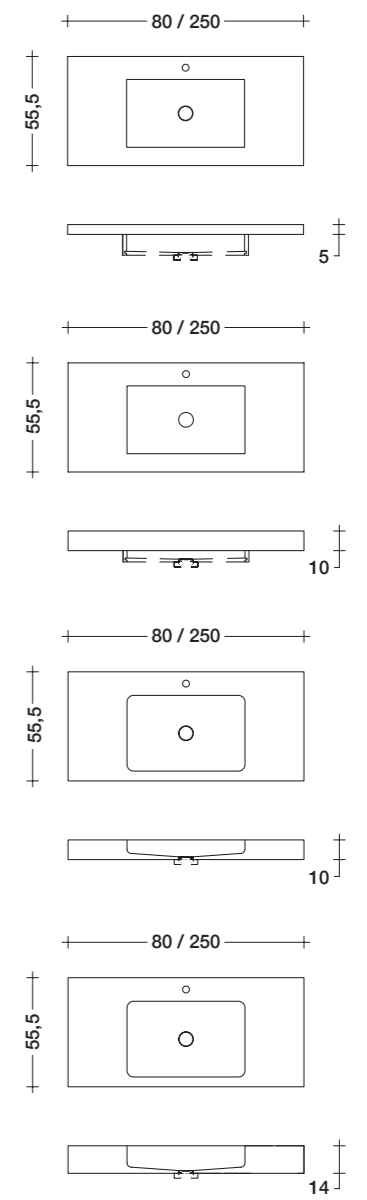
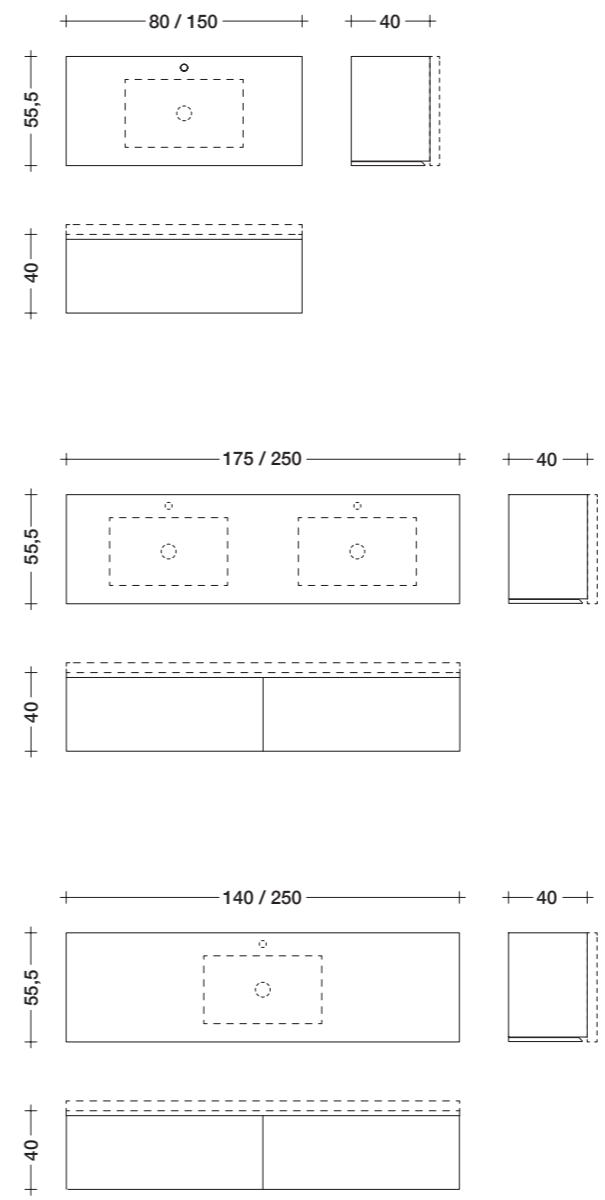

londra

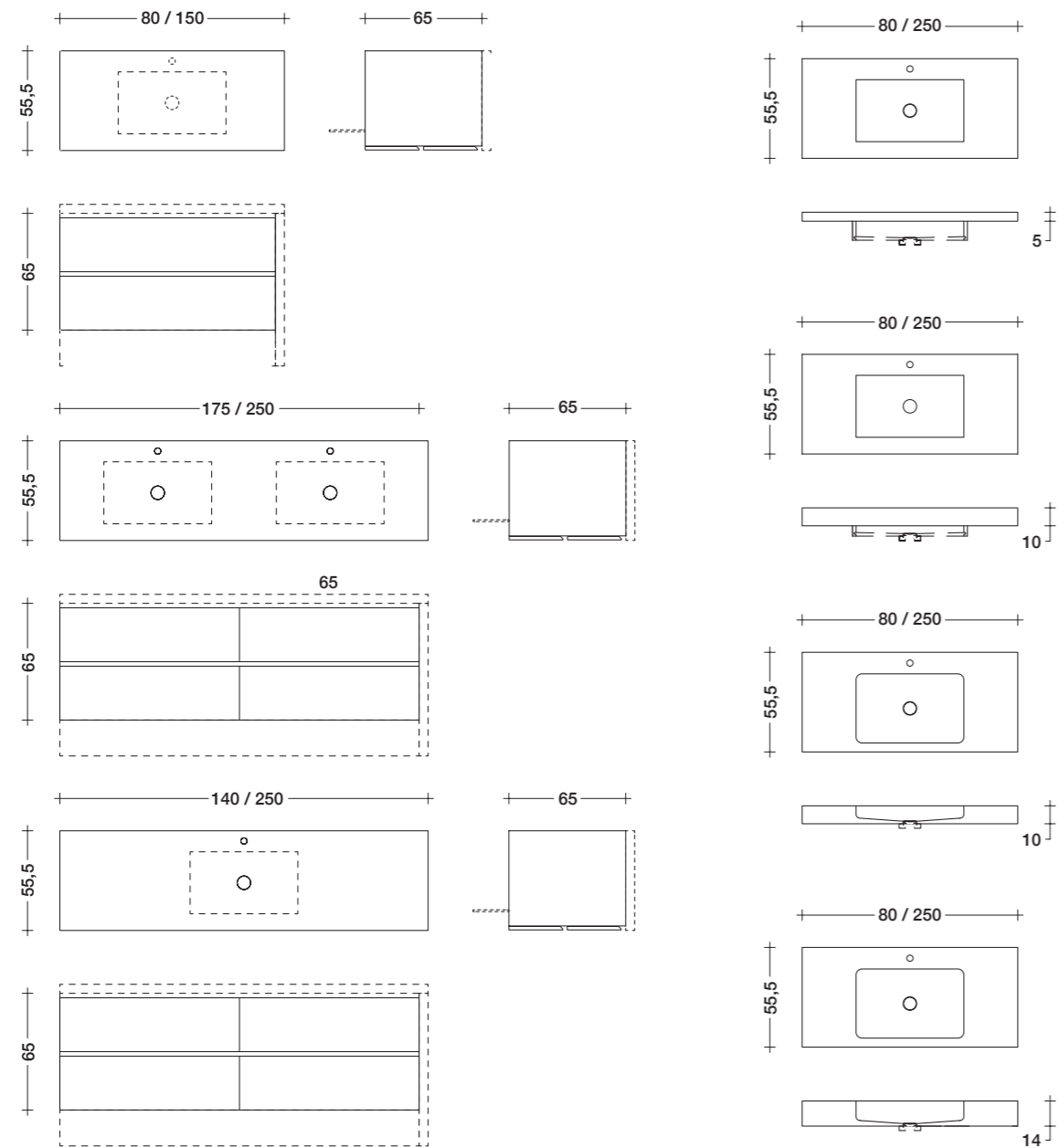

nebula

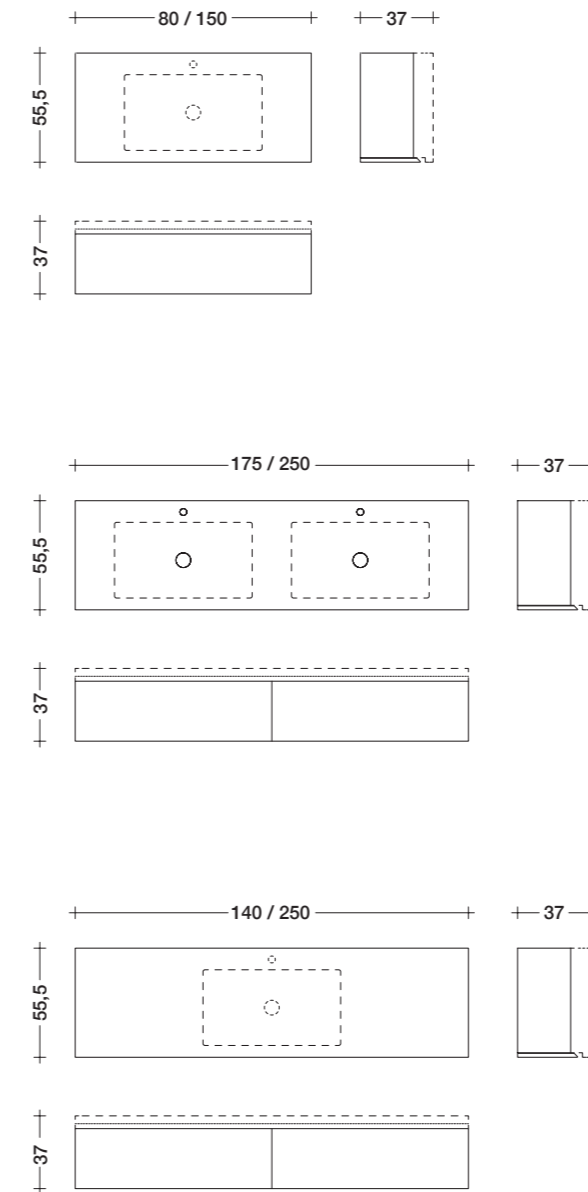

basic

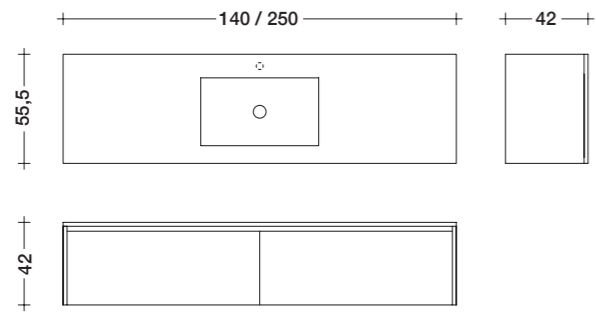
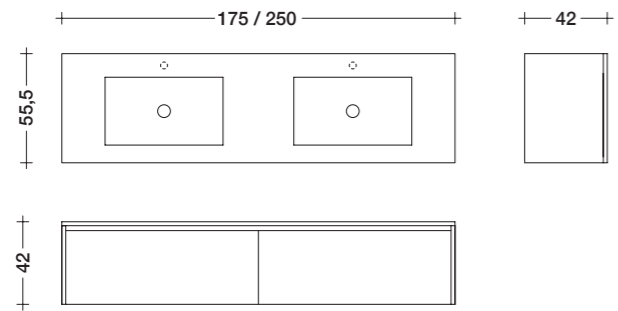
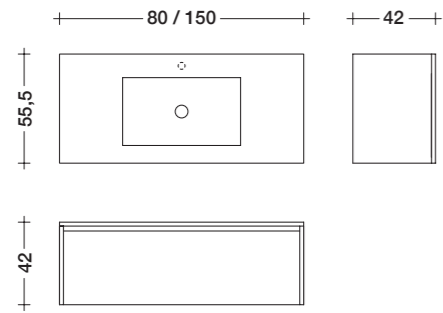

flair

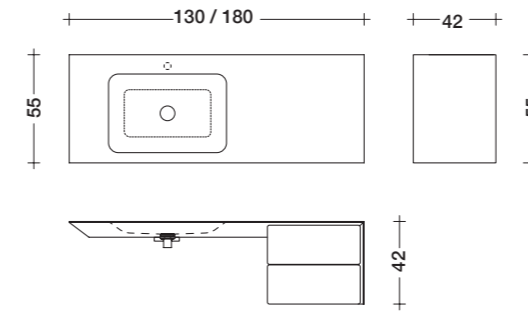

ramis

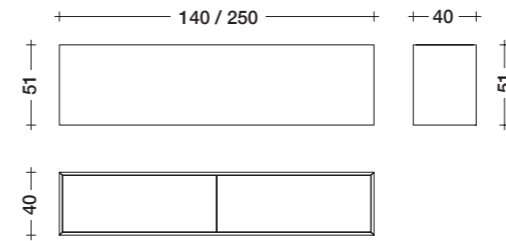
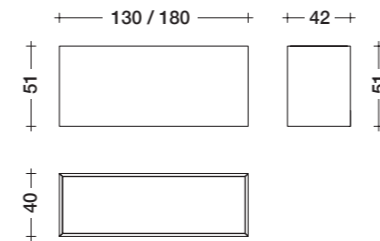

manta

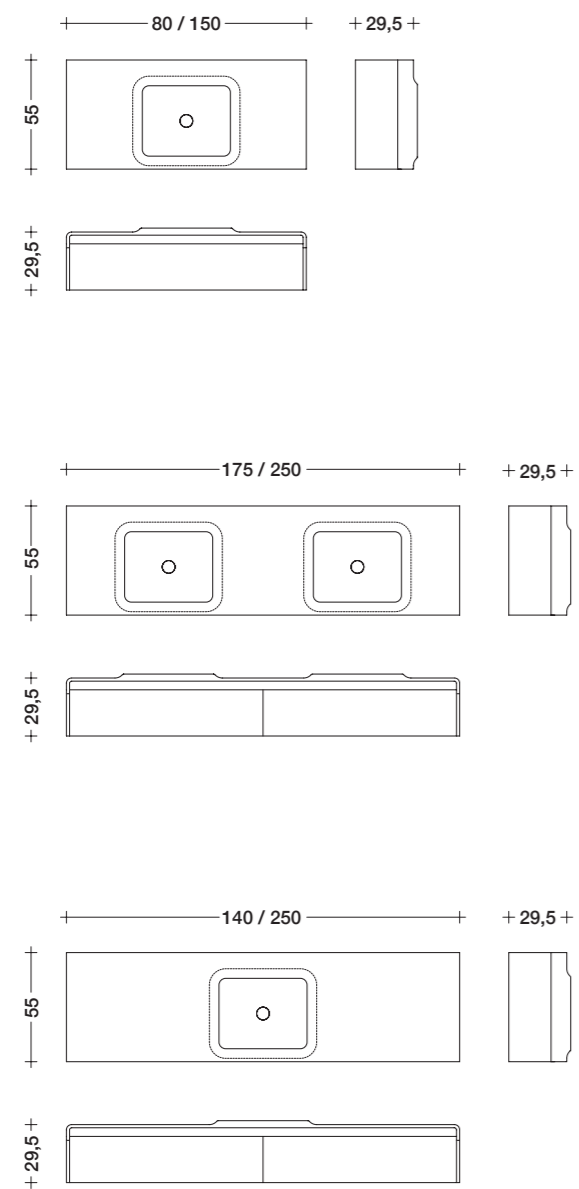

illumino

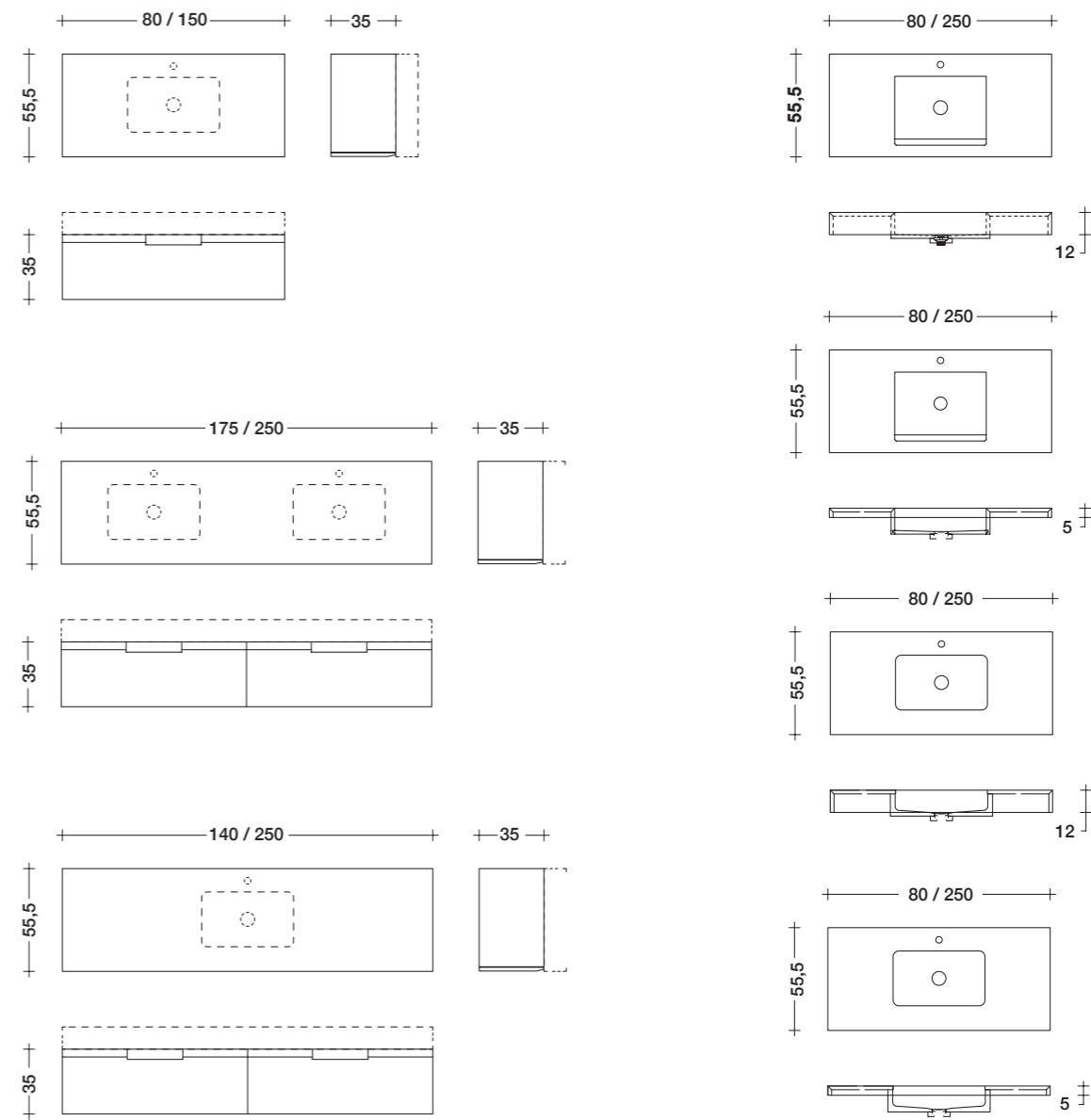



specchio **ho**

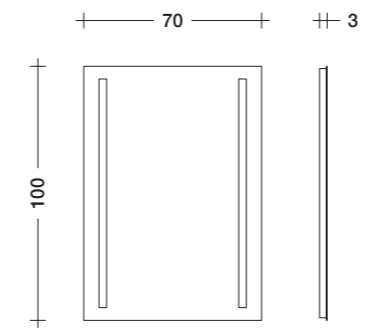

specchio **misa**

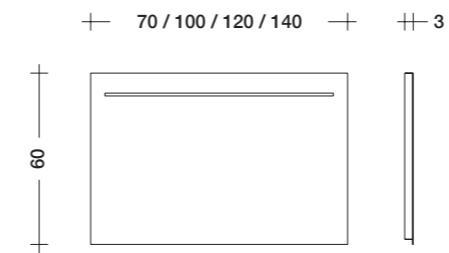

specchio **arno**

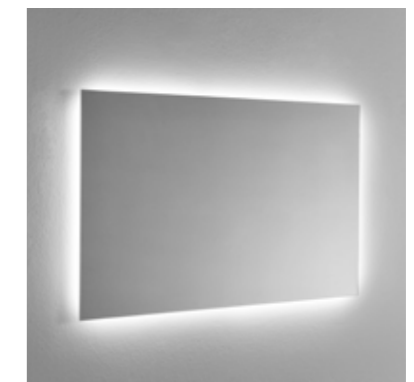
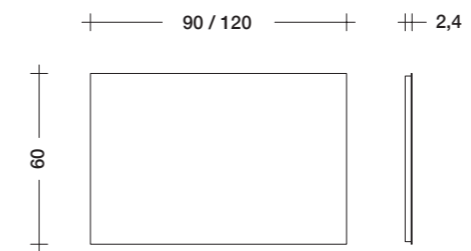

realizzabile anche su misura / custom size available

specchio **gange** L45xH100

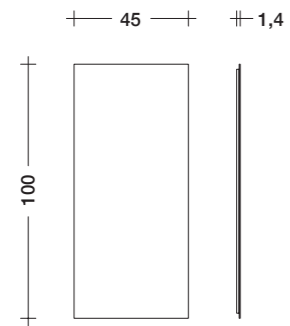

specchio **gange** L90xH90

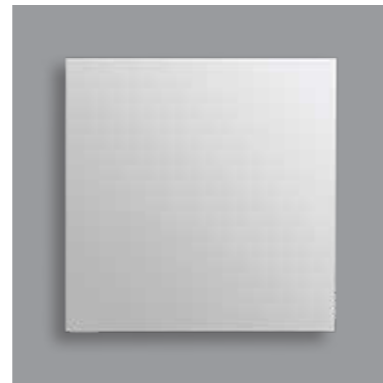
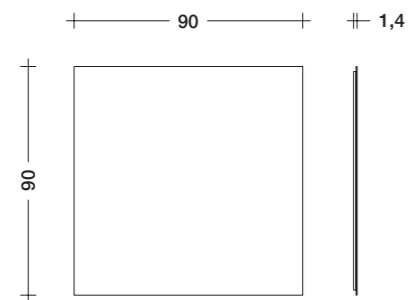

specchio **gange** ø100

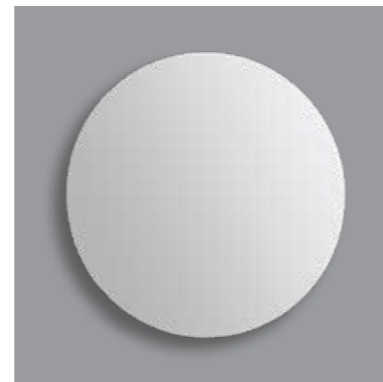
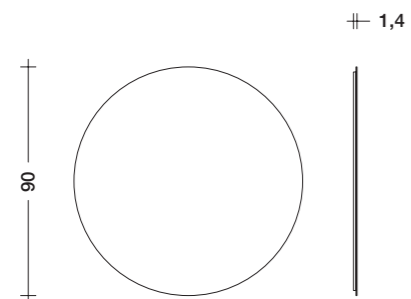

specchio **danubio** 90

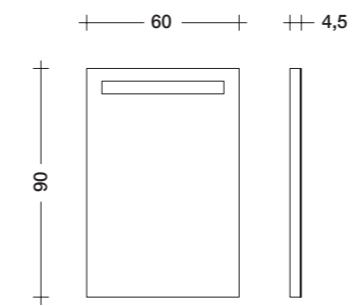

specchio **danubio** 120

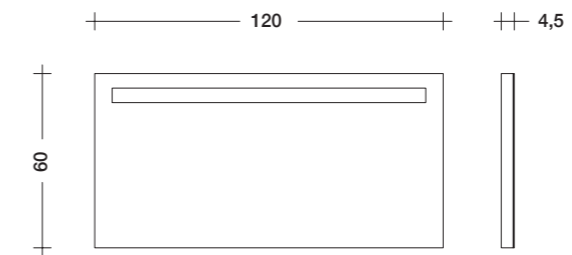

specchio **colorado** retroilluminato

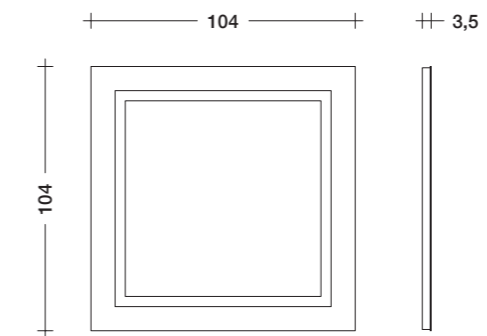

lampada **tolum** mod da 120

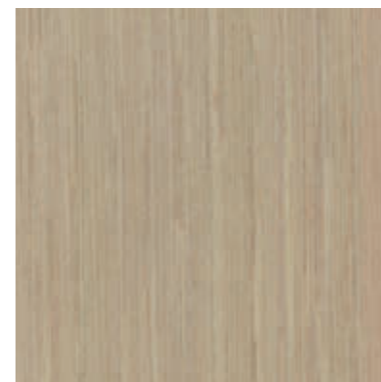
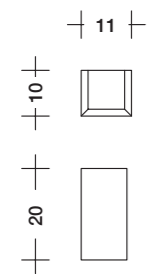

LIGHT GRAY GROOVE

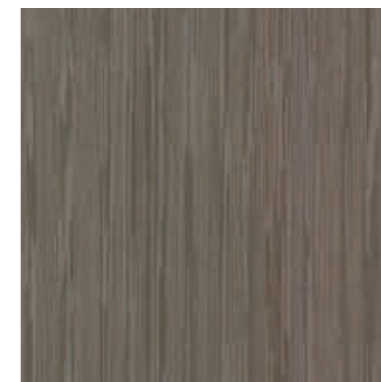

DARK GRAY GROOVE

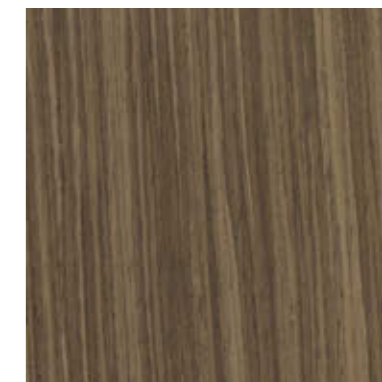

WALNUT GRAY GROOVE

lampada **tolum** mod da 33

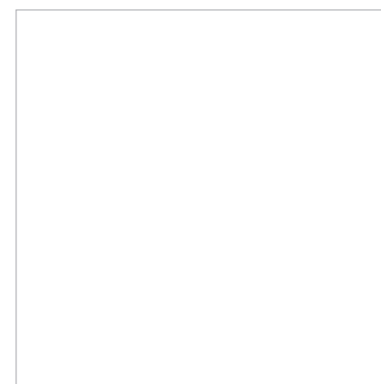
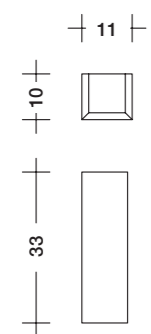

LACCATO BIANCO (RAL 9003)



LACCATO NERO (RAL 9005)



BIANCO CARRARA



BIANCO S.CATERINA



BIANCO ZARA

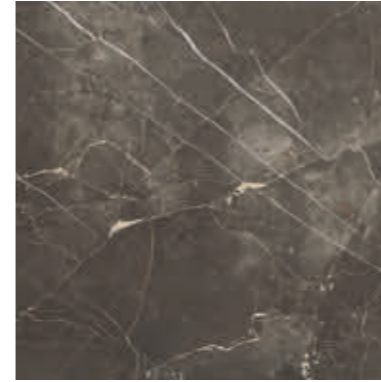

GRIGIO IMPERIALE



GIALLO SOLARE



GRIGIO STAR

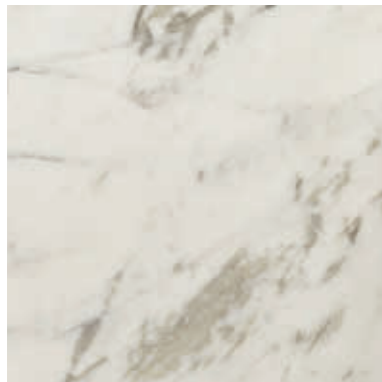

CALACATTA CONCI



CREMA PERLA



CREAM STONE



ONICE MIELE



ONICE NUVOLATO EXTRA

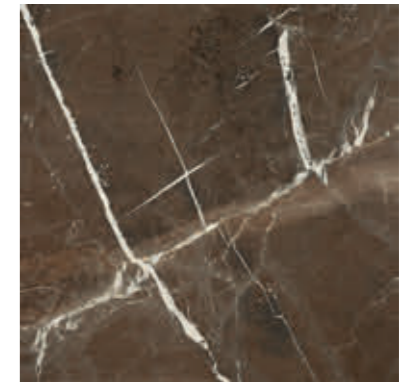

PIETRA BROWN



PIETRA BASALTINA



PIETRA FOSSENA FIAMMATA

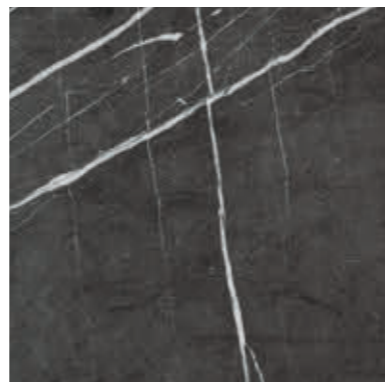

PIETRA GRAY

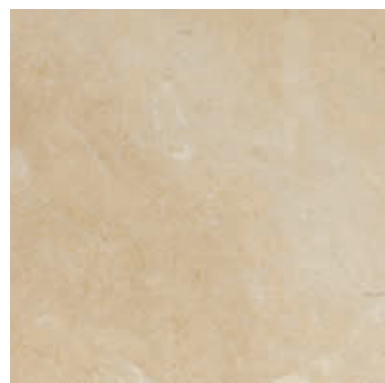

SAMARCANDA

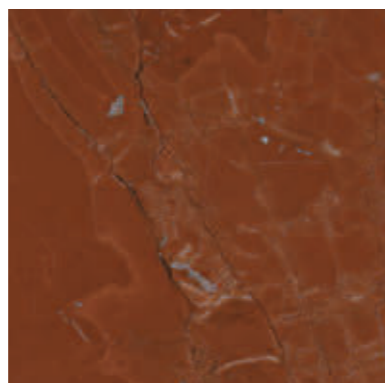

SASSO ROSSO



TRAVERTINO S.CATERINA AVORIO



TRAVERTINO S.CATERINA ONICIATO



TRAVERTINO S.CATERINA VENATO



TRAVERTINO TITANIO



concept and product design
I CONCI lab

roomset design and style
silvia angeli

graphic design and layout
cesare francolini

post production
lifeinpixel

print
grapho5

ver. 89D152

I CONCI | BAGNO

I Conci srl

Via Davide Albertario, 30
61032 Bellocchi di Fano (PU) Italy

Tel. +39 0721 855140
Fax +39 0721 854974

www.iconci.it
info@iconci.it

